

basicDIM ILD G2 5DPI

Compact control module with ambient light sensor and motion sensor



basicDIM ILD G2 SF1 20 5DPI WH



basicDIM ILD G2 SF1 20 5DPI BK



basicDIM ILD G2 SRC 20 5DPI WH

Product description

- _ For up to 64 DALI drivers, expandable with DALI-2 Input Devices (see data sheet 3.1 Wiring)
- _ Integrated application controller
- _ Flexible configuration via companionSUITE
- _ 2 DALI groups with adjustable offset
- _ Monitoring of ambient light and motion detection
- _ Infrared remote control for configuration and operation
- _ Power supply via DALI line
- _ Shutter for preventing occupancy detection in one direction included
- _ Small dimensions allowing easy and inconspicuous integration in luminaires
- _ For luminaires of protection class I and protection class II
- _ Wide range of accessories allowing extended application range
- _ 5 years guarantee (conditions at <https://www.tridonic.com/en/int/services/manufacturer-guarantee-conditions>)

Housing properties

- _ Casing: polycarbonate, black or white
- _ Type of protection IP20

Website

<http://www.tridonic.com/28003389>



basicDIM ILD G2 5DPI

Compact control module with ambient light sensor and motion sensor

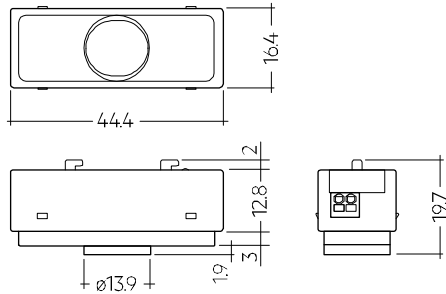

basicDIM ILD G2 SFI 20 5DPI WH/BK

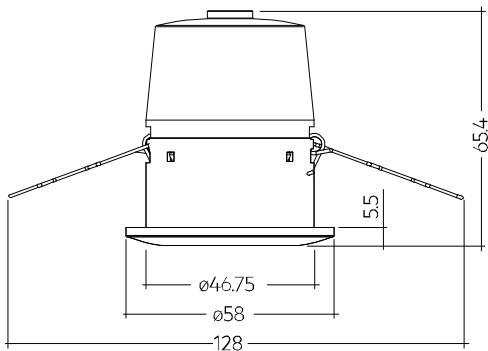

basicDIM ILD G2 SRC 20 5DPI WH

Ordering data

Type	Article number	Suitable for	Colour	Dimensions L x W x H	Packaging, carton	Weight per pc.
basicDIM ILD G2 SFI 20 5DPI WH	28003389	Luminaire installation	White	44.4 x 16.4 x 19.7 mm	15 pc(s).	0.010 kg
basicDIM ILD G2 SFI 20 5DPI BK	28003390	Luminaire installation	Black	44.4 x 16.4 x 19.7 mm	15 pc(s).	0.010 kg
basicDIM ILD G2 SRC 20 5DPI WH	28003391	Ceiling installation	White	58.0 x 58.0 x 65.4 mm	10 pc(s).	0.037 kg

Technical data

Sensor type	PIR sensor
Supply via	DALI cable
Supply voltage ^①	11.5 – 20.5 V
Current consumption (no LED)	max. 11 mA
Current consumption (with LED)	max. 12 mA
Mounting height	5 m
Mounting hole diameter	14.1 mm
Detection angle for PIR detection	84°
Detection angle for light measurement	30°
Detection range for light measurement ^②	2 – 2,000 lx
Min. temperature difference between ambient temperature and detected object	± 4 °C
Ambient temperature ta	-20 ... +50 °C
tc point	60 °C
Storage temperature ts	-25 ... +60 °C
Housing material body	PC polycarbonate
Housing material lens	PE polyethylene
Housing colour body	White (similar to RAL 9010)
Housing colour lens	White
Type of protection	IP20
Lifetime	up to 50,000 h
Guarantee (conditions at www.tridonic.com)	5 Year(s)

Approval marks**Standards**

EN 61347-2, EN 55015, EN 61000-3-2, EN 61000-3-3, EN 61547, IEC 60929

^① 14 – 20.5 V if use PBI1. Uin according to IEC 62386-101.

^② The measured value at the sensor head corresponds to approx. 10 to 10,000 lux on the surface measured.

REMOTECONTROL IR6

Accessory



Product description

- _ Optional infra-red remote control
- _ Switching on and off (On/Off button)
- _ Dimming (Up/Down button)
- _ Activation of automatic lighting control (Automatic button)
- _ Setting the threshold control point (Set button)
- _ IR range up to 20 m

Website

<http://www.tridonic.com/28000647>



Ordering data

Type	Article number	Dimensions L x W x H	Packaging, carton	Weight per pc.
REMOTECONTROL IR6	28000647	86.5 x 40.5 x 7.2 mm	500 pc(s).	0.019 kg

basicDIM ILD G2 Programmer

Accessory

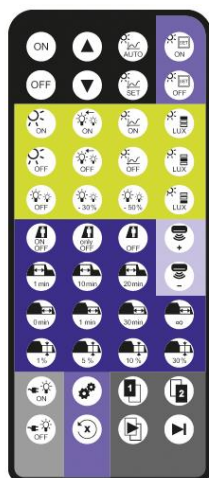

Product description

- _ Optional infra-red programming unit for basicDIM ILD G2
- _ Setting of predefined parameter values
- _ Programmable functions such as light level, time delay, P.I.R., bright-out, power up and grouping
- _ IR range up to 20 m

Website

<http://www.tridonic.com/28003484>

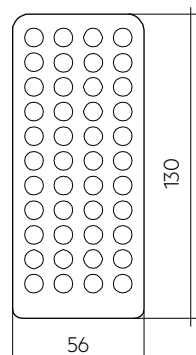

Ordering data

Type	Article number	Packaging, carton	Weight per pc.
basicDIM ILD G2 PROGRAMMER	28003484	150 pc(s).	0.04 kg

Approval marks**5DPI 14f Mounting Kit**

Accessory

**Product description**

- _ Mounting frame for attaching all 5DP 14f sensor directly to the luminaire housing
- _ Optional shutter to prevent presence detection in a specific direction (for PIR sensors)
- _ Glow wire test with 750 °C according to EN 61347-1

Website

<http://www.tridonic.com/28001558>

**Ordering data**

Type	Article number	Packaging, carton	Weight per pc.
5DPI 14f mounting kit	28001558	100 pc(s).	0.004 kg
5DPI 14f mounting kit black	28001575	100 pc(s).	0.004 kg

ACU Sensor Housing 14rs IP20

Accessory

**Product description**

- _ Mounting frame for wired 5DP 14f sensors allowing direct mounting to the ceiling
- _ Easy „click in“ installation of the sensor
- _ IP20
- _ Casing: plastic, white
- _ UV stabilized plastic
- _ DALI MSensor 5DPI 14 is powered via DALI circuit, basicDIM DGC Sensor 5DPI 14f powered via control unit
- _ Optional shutter to reduce the detection area, which makes it possible to reduce the detection area from 360° to 240° (for PIR sensors)
- _ Mounting kit with screws and decorative plugs
- _ 0.5 mm² wiring for the sensor
- _ Two 3 x 1.5 mm² clamps with cable management (2 entry points on opposite sides)
- _ Glow wire test with 750 °C according to EN 61347-1
- _ Sensor not included

Website

<http://www.tridonic.com/28001872>



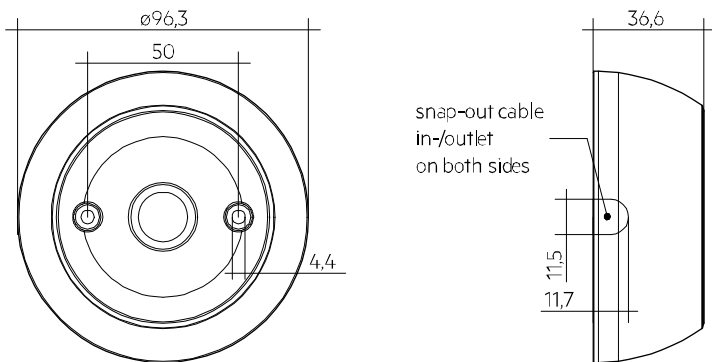

Ordering data

Type	Article number	Packaging, carton	Weight per pc.
ACU Sensor Housing 14rs IP20	28001872	57 pc(s).	0.054 kg

Housing base ACU 037 IP20 WH

Accessory

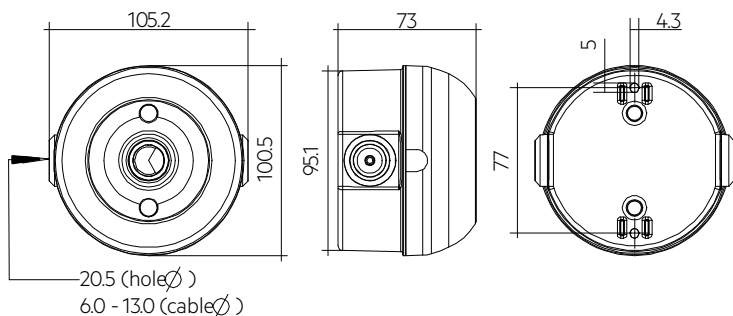

Product description

- _ Mounting base for wired 5/10/DPI/WDA sensors allowing direct mounting to the ceiling
- _ 2x mounting options for Tridonic standard control units-housing with mounting flaps (e.g. DALI PS3 or sceneCOM RTC) allowing vertical or horizontal fixation
- _ Vertical fixation possible using special fixation slots and horizontal fixation can be done using screw connection points in the bottom part of the accessory
- _ Housing provides IP 66, depending on the used Sensor and housing it can be less
- _ Casing: polycarbonate, white
- _ UV stabilized plastic
- _ Mounting kit with screws
- _ Casing passed glow wire test with 850 °C according to EN 61347-1
- _ compatible with: 28005943 Sensor Housing ACU 035 5DPI IP20 WH & 28005944 Sensor housing ACU 036 10DPI/WDA IP20 WH (not included in the scope of delivery)
- _ The dimensional drawing shows the final dimensions when mounted with 28005943 or 28005944
- _ System Solution: MSensor G3, basicDIM ILD G2/FSL, MSensor G3 SSM, basic DIM ILD G2 SSM, DALI PS3, airASECT, basicDIM IPS, basicDIM Wireless module G2, basicDIM Wireless passive module G2, sceneCOM S RTC
- _ Sensor not included

Website

<http://www.tridonic.com/28005945>



Ordering data

Type	Article number	Packaging, carton	Weight per pc.
Housing base ACU 037 IP20 WH	28005945	57 pc(s).	0.068 kg

Sensor Housing ACU 035 5DPI IP20

Accessory



Product description

- _ Mounting frame for wired 5DPI sensors allowing direct mounting to the ceiling
- _ Easy „click in“ installation of the sensor
- _ Additional bracket to fix sensor, to prevent its drop inside the housing
- _ IP20
- _ Casing: polycarbonate, white
- _ UV stabilized plastic
- _ Mounting kit with screws and decorative plugs
- _ 0.5 mm² wiring for the sensor
- _ Two 3 x 1.5 mm² clamps with cable management (2 entry points on opposite sides)
- _ Optional shutter to reduce the detection area, which makes it possible to reduce the detection area from 360° to 240° (for PIR sensors)
- _ Casing passed glow wire test with 850 °C according to EN 61347-1
- _ compatible with Housing base ACU 037 IP20 WH Art.-No.: 28005945
- _ Sensor not included

Website

<http://www.tridonic.com/28005943>

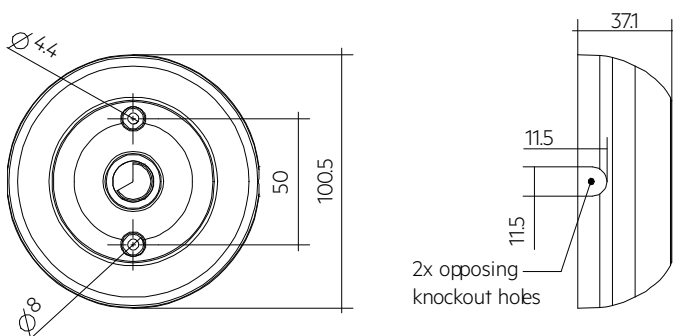

Ordering data

Type	Article number	Packaging, carton	Weight per pc.
Sensor Housing ACU 035 5DPI IP20 WH	28005943	57 pc(s).	0.052 kg

basicDIM ILD G2 CWM 20 PBI1

Accessory

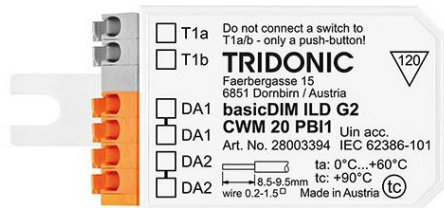

Product description

- _ Push Button Interface (PBI) for ILD G2 and ILD G2 FSL system
- _ Flexible configuration via the ILD G2 and ILD G2 FSL in combination with the companionSUITE
- _ Short push button action: automatic / fade off (factory default)
- _ Long push button action: dim up / dim down (factory default)
- _ Double push button action: set new target value for light regulation (factory default)
- _ Through-wiring DA1 / DA2 possible
- _ Detachable mounting flaps, allow installation in flush-mounted boxes and luminaires

Note

- _ A permanent short circuit between T1a and T1b results in limited function
- _ Only push buttons can be used

Website

<http://www.tridonic.com/28003394>

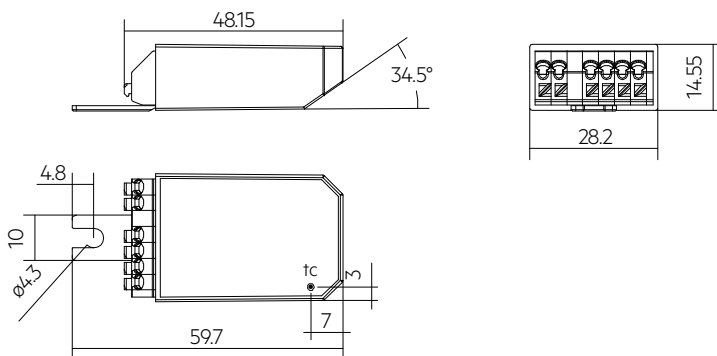

Ordering data

Type	Article number	Packaging, carton	Weight per pc.
basicDIM ILD G2 CWM 20 PBI1	28003394	15 pc(s).	0.012 kg

Approval marks



1. Standards

EN/IEC 61347-2-11:2001
 EN 55015:2013
 EN 61000-3-2:2014 Part 3-2
 EN 61000-3-3:2013 Part 3-3
 EN 61547:2009

1.1 DALI standard

The basicDIM ILD G2 is designed to control control gear with DALI standard IEC 60929 (DALI V0), IEC 62386 (DALI V1/DALI-2).

1.2 Glow wire test

according to EN 61347-2-11 passed for temperatures up to 850°C.

2. Common

The basicDIM ILD G2 provides the basis for an easy-to-use and cost-effective lighting system with motion detection. When the sensor detects movement it triggers a individual adjustable motion detection profile in the control unit.

As the amount of natural ambient light changes the illuminance from the artificial lighting system is adjusted.

The connected luminaires can be switched on and off via momentary-action switch or remote control possible.

IR is always active.

This sensor provides measurement of ambient light, motion detection via PIR sensor and IR remote control input as well as a LED output for signalisation. basicDIM ILD G2 is created for following main applications:

Low height buildings such as

- Corridors, passages und Garages
- Office buildings and educational institutions



The basicDIM ILD G2 was developed and tested exclusively for Tridonic MSensor G3, XC G3 and PBI1. The use of other sensors and push button modules can lead to errors.

3. Installation

- The basicDIM ILD G2 must not be connected to the mains. It is supplied directly via the DALI power supply.
- DALI is not SELV.
The installation instructions for mains voltage therefore apply.
- Please ensure that the detection range of the sensor lies in the lighting area of the controlled luminaires.
- Please ensure that the detection ranges of the sensors do not overlap. This may have influence to the lighting control.
- When installed at a height other than the recommended installation height, the presence sensor might show different characteristics. When mounted at a higher level, its sensitivity is reduced. If mounted at a lower level, its range is reduced.
- Heaters, fans, printers and copiers located in the detection zone may cause incorrect presence detection.
- Avoid direct illumination of the light source on the sensor including housing.
- Additional IR sources can disturb the sensor.
- The maximum permissible current consumption of all components on the bus must not exceed the maximum permissible current of the connected DALI Power Supply.
- When using pre-addressed DALI components, double addressing may occur. This error can be corrected by pressing the reset button. Commissioning must be carried out again.
- Additional IR sources can interfere with the sensor.
- The maximum permissible current consumption of all components on the bus must not exceed the maximum permissible current of the connected DALI Power Supply.
- When using pre-addressed DALI components, double addressing may occur. This error can be corrected by pressing the reset button (basicDIM ILD G2 Programmer). The commissioning must be carried out again.

3.1 Wiring

Room application:

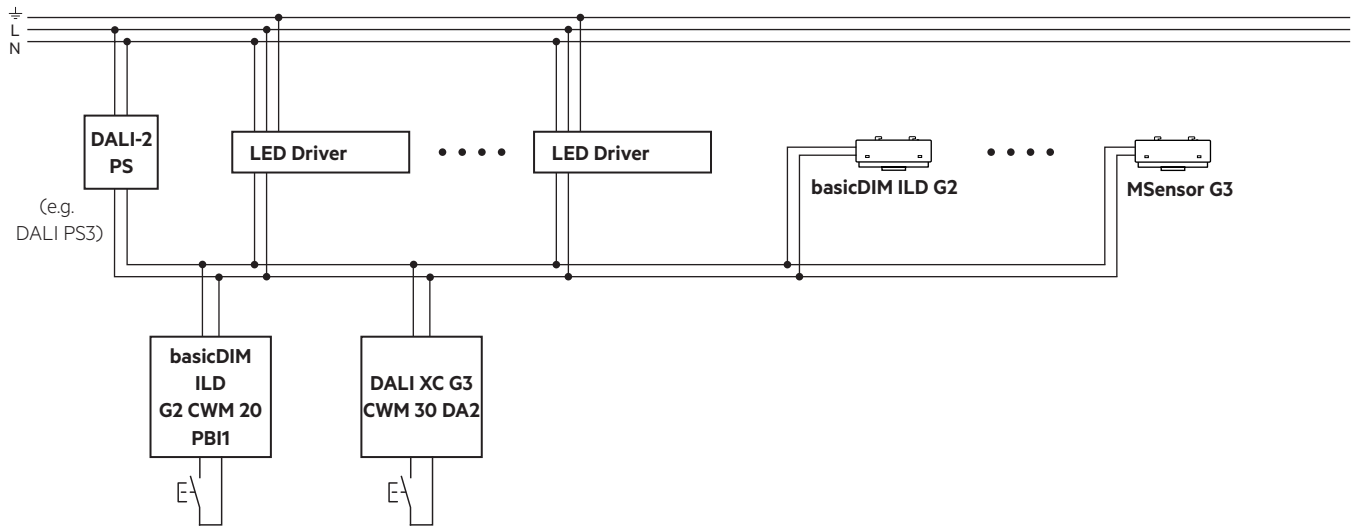

Single / free-standing luminaires, driver with integrated power supply (DALI):

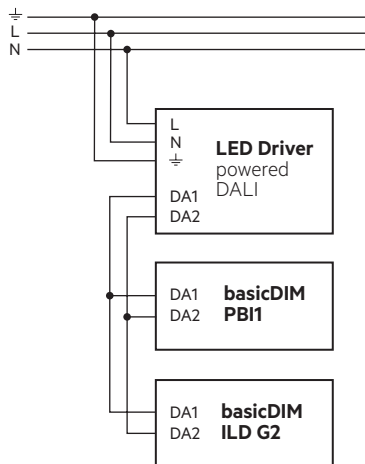

Single / free-standing luminaires, driver with separate power supply (DALI):

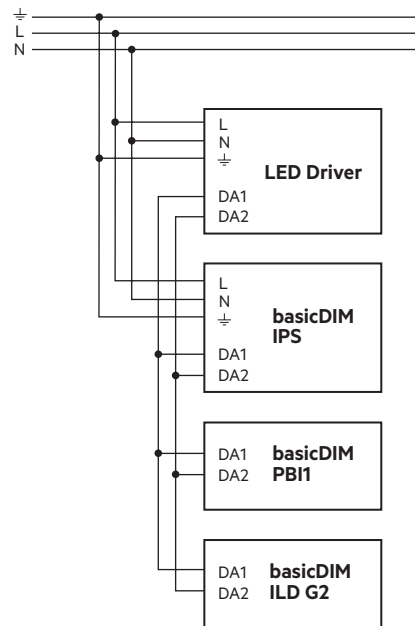

Maximum number of connected devices:

Devices	Number
ILD G2	1 pc.
DALI PS	2 pc. (max. 250 mA)
LED driver	64 pcs.
Input devices (MSensor G3, XC G3)	8 pcs.
PBI1	4 pcs.

DALI repeater must not be used.

Compatible accessories:

- MSensor G3 as additional, slave motion detector
- XC G3 as multi channel push button interface

Factory settings for DALI XC G3:

Button	Action	Factory settings
T1	Short press	Automatic / Fade off
	Long press	Dim up / Dim down
	Double click	SET (store new value for constant light control)
T2	Short press	Automatic
	Long press	not used
	Double click	not used
T3	Short press	not used
	Long press	Dim up / Dim down
	Double click	not used
T4	Short press	Automatic (switch luminaire on or change to automatic mode)
	Long press	not used
	Double click	SET (store new value for constant light control)

Factory settings for PBI1:

Button	Action	Factory settings
T1	Short press	Automatic / Fade off
	Long press	Dim up / Dim down
	Double click	SET (store new value for constant light control)

3.2 Wiring type and cross section for rc version

For wiring use stranded wire with ferrules or solid wire from 0.2 to 1.5 mm².

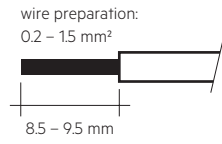

3.3 Wiring type and cross section for f version

For wiring use stranded wire with ferrules from 0.2 to 0.5 mm² or solid wire from 0.14 to 0.5 mm².

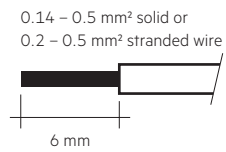

3.4 Mounting variants luminaire installation sensor:

Variant 1:

Size of the sheet: 0.8 – 1.8 mm

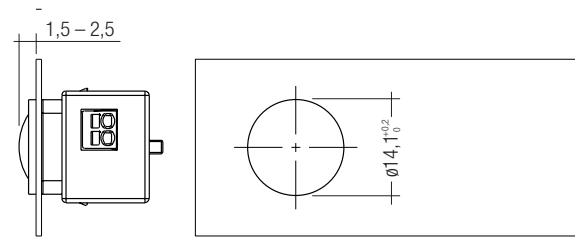

Variant 2:

Size of the sheet: 0.8 – 3.0 mm

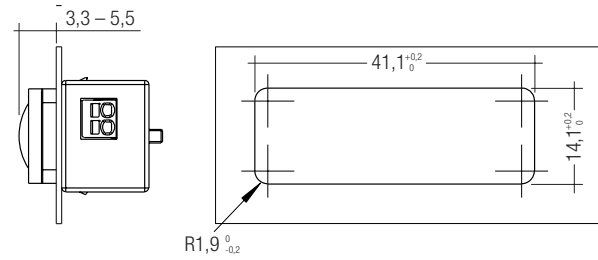

Variant 3:

Size of the sheet: 0.6 – 0.8 mm

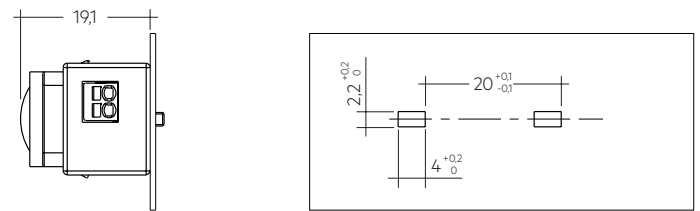

3.5 Mounting in luminaire housing with Mounting Kit:

Size of the sheet: 0.8 – 2.0 mm

Dimension drawing for needed mounting opening

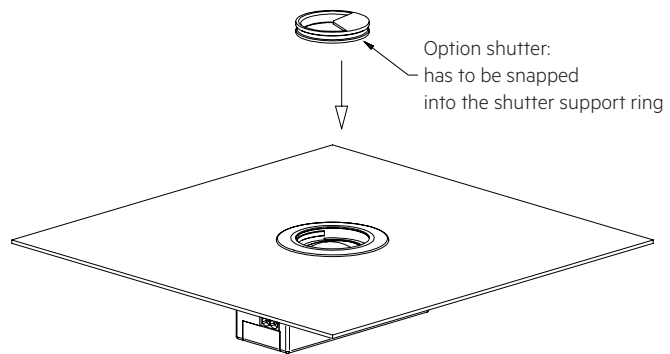
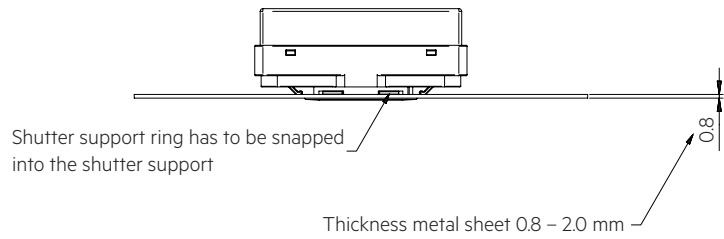
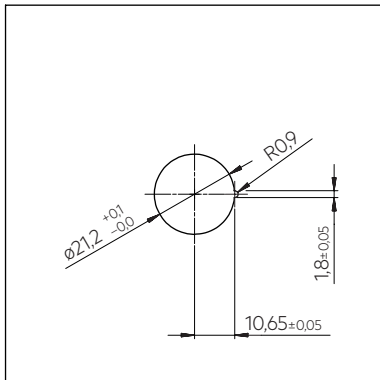

3.6 Mounting Kit mounting

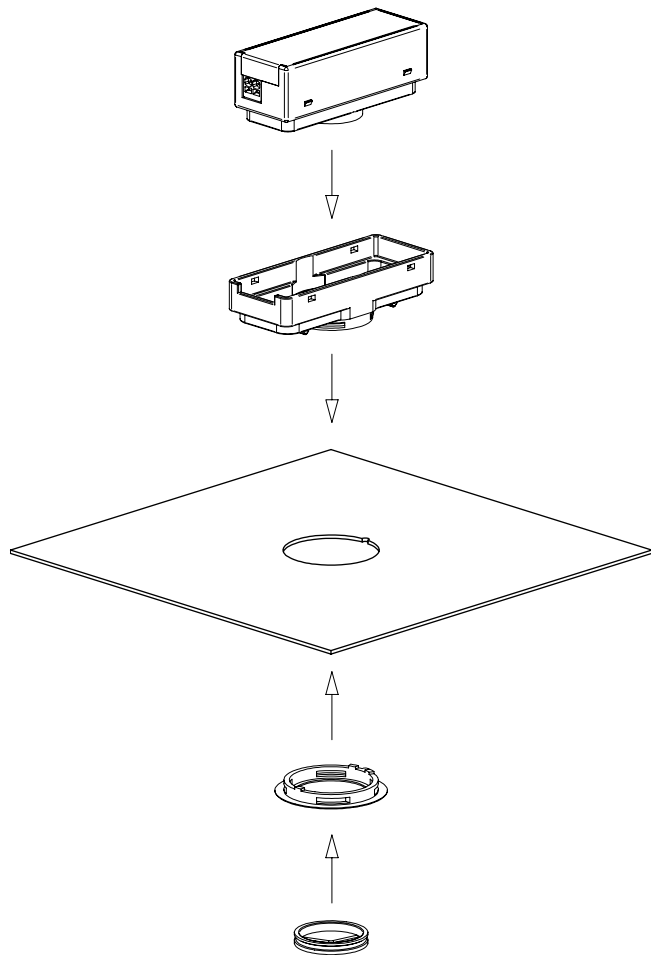

3.7 Mounting Kit Shutter

Area which is masked by the shutter.

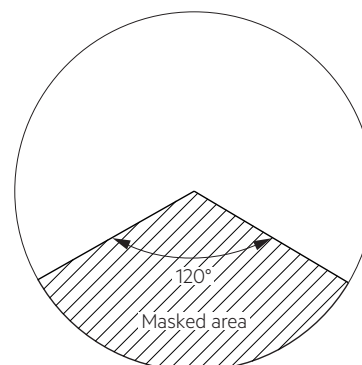
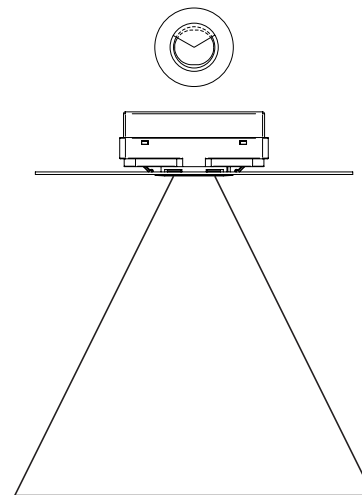

3.8 Wiring and mounting ACU Sensor Housing 14rs IP20

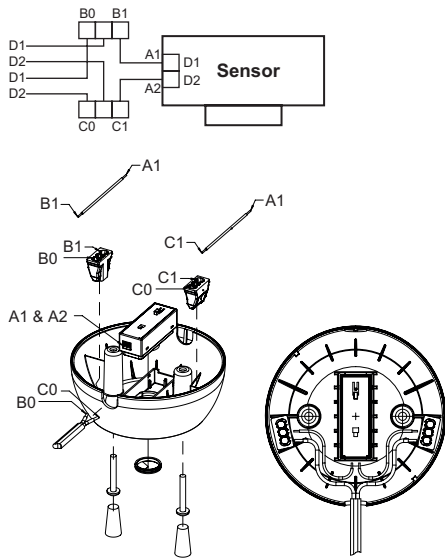

3.9 Mounting in class II luminaire

The Sensor provides basic insulation as required by IEC 62386-101 and defined in IEC 61347-1.

If the sensor is built in to a class II luminaire which has to provide double or reinforced insulation it has to be considered that the Sensor is not a class II device. Still the Sensor can be used for such projects as the front and the back of the sensor is tested to fulfill the class II requirements for double or reinforced insulation.

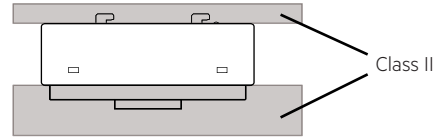

4. Light level recognition area

The measurement range is between 2 and 2,000 lx.
Measured at the sensor head.

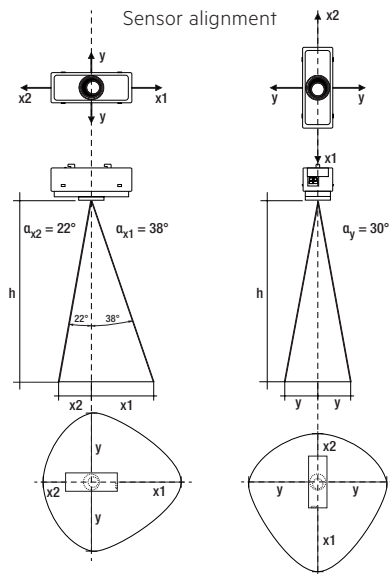

h *	x1	x2	y	d
1.7 m	1.3 m	0.7 m	1.0 m	3.0 m
2.0 m	1.6 m	0.8 m	1.2 m	3.6 m
2.3 m	1.8 m	0.9 m	1.3 m	4.1 m
2.5 m	2.0 m	1.0 m	1.4 m	4.5 m
2.7 m	2.1 m	1.1 m	1.6 m	4.9 m
3.0 m	2.3 m	1.2 m	1.7 m	5.4 m
3.5 m	2.7 m	1.4 m	2.0 m	6.3 m
4.0 m	3.1 m	1.6 m	2.3 m	7.2 m

* The recommended maximum room height for office applications is 3 m and for corridor applications for example 4 m. Up to 2 m mounting height presence is detected and over 2 m motion is detected.

Calculation of the diameter (light area):

$$x1 = \tan(\alpha_{x1}) \times h$$

$$x2 = \tan(\alpha_{x2}) \times h$$

$$y = \tan(\alpha_y) \times h$$

Calculation of the diameter (motion area):

$$d = 2 \times \tan(0,5 \times \alpha) \times h$$

Example for light and motion detection area at height of 1.7 m:

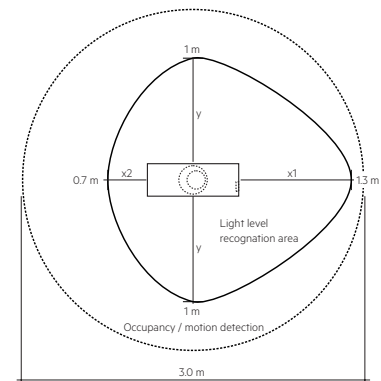

4.1 Presence / motion detection

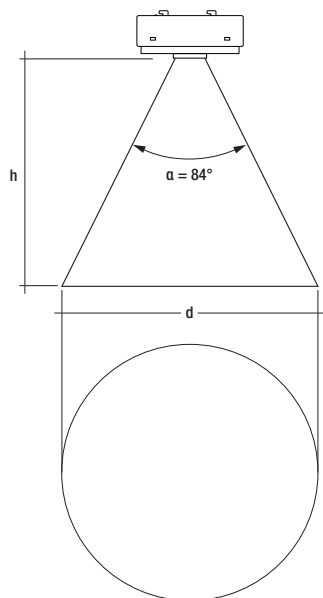

4.2 Motion detection

For motion detection PIR technology is used. PIR Lens is made to detect moving people in working areas such as corridors, passages, garages, office buildings or educational institutions with the following performance criteria:

- Ceiling height from up to 5 m
- Movement of human body:
 - up to 2 m mounting height: detection of slight motion.
 - above 2 m mounting height: no slight motion (no sitting person) detection.
- Movement ≥ 1.0 m/s for mounting heights up to 5 m

4.3 Status LED's

The status LED is deactivated by default. There is a LED built in to indicate different status information to the user. This LED is controlled from the sensor itself.



To not have any influence from LED to the light measurement, LED is disabled while light sensor is measuring by default.

Status	Pattern	Incident
-	-	Normal operation
Single red flash	0.2 s on. all 6 s	Motion has been detected
Permanent red flashing	0.2 s on. all 1 s	System error: - Second basicDIM ILD G2 available - Stuck button time out
Long green flashing	1 s on. all 6 s	Bright-out active
Orange flashing	0.5 s on. all 0.5 s	Start-up, Grouping, Test mode, Reset active application controller deactivated
Short blue flashing	0.2 s	Receive infrared command from basicDIM ILD G2 Programmer or IR6

4.4 User-definable parameters

Parameter	Range (Factory Settings)	Description
power-up behavior	on / off (on)	If the parameter is set to "on", the luminaire switches on after a mains break. If the parameter is set to "off", the luminaire does not switch on after a mains break.
Presence lux level	Absence level / 1000 lux (500 lux)	Value used by the light sensor to regulate the presence level of the luminaire. On account of the room conditions and the installation height, the illuminance in the workspace may, however, be three to four times higher.
presence level	1 to 100 % (100 %)	Brightness value that the ILD G2 occupies as soon as presence has been detected.
absence level	1 to 100 % (1 %)	Brightness value that the ILD G2 occupies while the switch-off delay is running.
fade-in time	0 to 15 (1)	Period of time starting as soon as presence is detected. During fade-in time, the luminous intensity fades to the presence value. 1 = 0.7 s 2 = 1 s 3 = 1.4 s 4 = 2 s 5 = 2.8 s 6 = 4 s 7 = 5.7 s 8 = 8 s 9 = 11.3 s 10 = 16 s 11 = 22.6 s 12 = 32 s 13 = 45.3 s 14 = 64 s 15 = 90.5 s
fade time	0 to 15 (8)	Period of time during which the luminous intensity fades from the presence value to the absence value. 1 = 0.7 s 2 = 1 s 3 = 1.4 s 4 = 2 s 5 = 2.8 s 6 = 4 s 7 = 5.7 s 8 = 8 s 9 = 11.3 s 10 = 16 s 11 = 22.6 s 12 = 32 s 13 = 45.3 s 14 = 64 s 15 = 90.5 s
run-on time	15 s to 60 min (20 min)	Time that begins to run from the last moment that presence was detected. After the run-on time the fade-off time is started. If another presence is detected in the room during run-on time, the run-on time is started again.
switch-off delay	off / 15 s to 60 min / never OFF (off)	Time in which the absence value is held. After expiration, the luminaire is either switched off or the absence value is held (never OFF).
fade-off time	0 to 15 (2)	Period of time starting after the run-on time. During the fade-off time, the luminous intensity fades to off. 1 = 0.7 s 2 = 1 s 3 = 1.4 s 4 = 2 s 5 = 2.8 s 6 = 4 s 7 = 5.7 s 8 = 8 s 9 = 11.3 s 10 = 16 s 11 = 22.6 s 12 = 32 s 13 = 45.3 s 14 = 64 s 15 = 90.5 s
constant light control	on / off (on)	Enables or disables the constant light control
bright-out	on / off (on)	If the parameter is set to "on", the luminaire switches off as soon as the light level exceeds the bright-out threshold of the set point for longer than 10 minutes. This could be the case if, for instance, the room is adequately illuminated by sunlight. If the bright-out threshold falls below 100 % of the set point, the luminaire switches back on again.
bright-out threshold	110 to 400 % (150 %)	Bright-out threshold used by the bright-out function
bright-out-off delay time	0 to 3,600 s (600 s)	Period of time that the light level must exceed the bright-out threshold to activate bright-out.
group 2 offset mode	fixed / converging (converging)	This parameter specifies how the group 2 offset value behaves if the light is dimmed up. If the parameter is set to "converging", the dimming level of group 2 will keep on rising even if group 1 has already reached a dimming level of 100 %. The brightness difference will be gradually reduced up to the point where both group 1 and group 2 reach the same dimming level of 100 % which effectively reduces the group 2 offset value to zero. This way, the offset will "converge". If the parameter is set to "fixed", the offset is "fixed". The brightness difference between group 1 and group 2 will stay at the value defined for the group 2 offset value. If the group 2 offset value was set to e.g. 30 %, the group 2 dimming level will always stay 30 % below the dimming level of group 1. If group 1 has reached a dimming level of 100 %, the dimming level of group 2 will stop rising because otherwise the offset would be reduced to less than the defined group 2 offset value.
group 2 offset value	0 to 95 % (30 %)	Adjustable brightness difference between group 2 and group 1

4.5 Possible push button configuration

Short Press	Long Press	Double Press
Automatic mode	Dimming up	Set target value
Recall max. level	Dimming down	No function
Off	Dimming up / dimming down	
Recall max. level / off	No function	
On with fade		
Off with fade		
Automatic mode / off with fade		
No function		

5. Miscellaneous

5.1 Disposal of equipment



Return old devices in accordance with the WEEE directive to suitable recycling facilities.

5.2 Additional information

Additional technical information at www.tridonic.com → Technical Data

Guarantee conditions at www.tridonic.com → Services

Lifetime declarations are informative and represent no warranty claim.
No warranty if device was opened.