

**basicDIM Wireless User Interface LR**  
Casambi Ready wireless user interface



**Product description**

- \_ Can be integrated in Casambi systems (Casambi Ready)
- \_ Battery powered, wireless wall switch
- \_ Forms automatically a wireless communication network with up to 250 nodes
- \_ Controls all types of basicDIM Wireless devices
- \_ 4 scenes
- \_ Dim up / down
- \_ Colour temperature control
- \_ 5 years guarantee (conditions at <https://www.tridonic.com/en/int/services/manufacturer-guarantee-conditions>)
- \_ We will provide security updates for the next five years after the date of purchase of this product

**Website**

<http://www.tridonic.com/28005548>



**basicDIM Wireless User Interface LR**

Casambi Ready wireless user interface

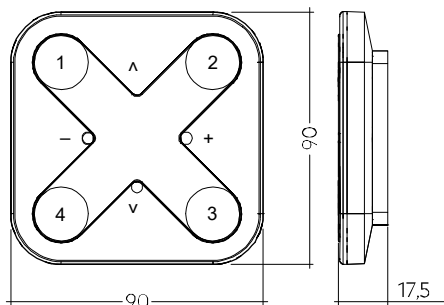

**Ordering data**

Type	Article number	Colour	Packaging, carton	Weight per pc.
basicDIM Wireless UI BK	28005548	Black	50 pc(s).	0.087 kg
basicDIM Wireless UI WH	28005549	White	50 pc(s).	0.087 kg

**Technical data**

Battery Lithium-ion	CR 2430
Battery life	2 – 5 years, depending on usage
Radio transceiver operating frequencies	2.4 – 2.483 GHz
Max. output power radio transceiver (E.I. R.P.) <sup>①</sup>	< + 20 dBm
Radio protocol	Bluetooth 4.0 or 5.0 Low Energy (BLE)
Capable for mesh network	Up to 250 nodes / Standard networks and Long Range
Wireless range, in open air	≤ 60 m
Ambient temperature ta	0 ... +40 °C
Lifetime	50,000 h
Guarantee (conditions at <a href="http://www.tridonic.com">www.tridonic.com</a> )	5 Year(s)
Dimensions L x W x H	90 x 90 x 12 mm
Type of protection	IP20

**Approval marks**



① E.I.R.P.: Equivalent Isotropically Radiated Power.

## 1. Common

### 1.1 Description

basicDIM Wireless User Interface is a wireless user interface that brings huge flexibility to interior design as furniture can be replaced or even walls can be rebuilt without having to take wiring of switches or switch placement into account. The switch can be kept wherever the user needs it and it gives direct access to all the important Tridonic lighting control functionalities.

From production number #2917 on or higher, the basicDIM Wireless User Interface is fully compatible with networks which support up to 250 nodes (Evolution networks). Devices with a lower production number are only compatible with networks which support up to max. 127 devices (Classic networks). The production number can be found on the battery tray of the device.

If the basicDIM Wireless User Interface is used with different types of basicDIM Wireless devices in an Evolution network, their compatibility has to be checked before. If a device is not compatible with Evolution networks, it can be only used in Classic networks.

Multiple devices automatically form a mesh network that can be controlled from any point. These networks communicate wirelessly directly with the smartphone or tablet. Therefore, an external gateway or wireless LAN network is not required.

## 2. Thermal details and lifetime

### 2.1 Expected lifetime

#### Expected lifetime

Type	ta	40 °C
basicDIM Wireless UI	tc	40 °C
	Lifetime	50,000 h

The device is designed for a lifetime stated above under reference conditions and with a failure probability of less than 10 %.

The battery lifetime is depending on the usage.  
The battery is not included in the standard guarantee.

## 3. Functions

### 3.1 Basic functions

The preset buttons of basicDIM Wireless Interface can be configured via the control app.

A light indicates the selected preset.

Dim up, Dim down:

- Smooth dimming of last chosen preset

Multipurpose buttons:

- Change of colour temperature in steps of 25 Kelvin
- Change of the indirect/direct ratio

Preset Buttons:

- Individual luminaire control
- Group control
- Control of all lamps
- Recall scenes
- Recall animations

### 3.2 Smart functions

#### 3.2.1 Dimming

Hold the Dim down or Dim up button:

- Smooth dimming of last chosen preset, cycle takes 5 seconds

Tap the Dim down button:

- Chosen preset goes to 0 %

Tap the Dim up button:

- Chosen preset goes to 100 %

#### 3.2.2 Preset buttons

Tap:

- The chosen preset (lamp control, group control, all lamps, scene recall or animation recall) will turn on

Tap again:

- The chosen preset (lamp control, group control, all lamps, scene recall or animation recall) will turn off

#### 3.2.3 Colour Temperature

Hold the Multipurpose button:

- Changes colour temperature smoothly, cycle takes 5 seconds

Tap the upper Multipurpose button:

- Changes to the warmest colour temperature

Tap the lower Multipurpose button:

- Changes to the coldest colour temperature

#### 3.2.4 Indirect/Direct Ratio (sum of indirect/direct in all cases 100 %)

Hold the upper Multipurpose button:

- Dims up smoothly the indirect lighting, cycle takes 5 seconds

Hold the lower Multipurpose button:

- Dims up smoothly the direct lighting, cycle takes 5 seconds

Tap the upper Multipurpose button:

- The indirect part goes to max level

Tap the lower Multipurpose button:

- The direct part goes to max level

#### 3.2.5 Turn Off

Press the Dim down and Dim up button for more than 1 second:

- Turns all lights off in selected network

## 4. Installation

### 4.1 Placement

basicDIM Wireless User Interface is equipped with magnets for easy attachment to a mounting bracket. The mounting bracket is included.

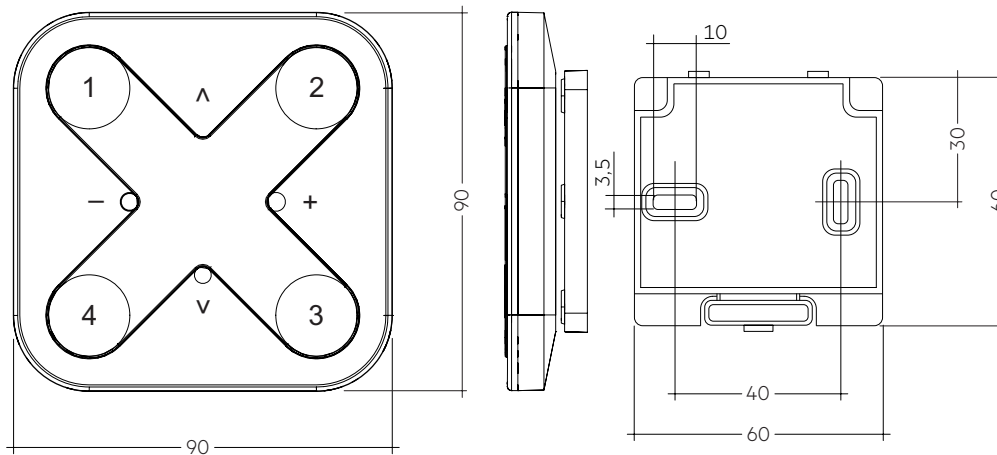

### 4.2 Installation note

Max. torque at the clamping screw: 0.5 Nm with screws (max.  $\varnothing$  3 mm).

### 4.3 Battery

Remove the locking screw located on the battery lid cover using a cross-head screwdriver. Slide the cover downwards and replace the old battery. The battery type is CR2430. Always replace the battery with the same type. Reinstall the battery lid cover and tighten the screw. Properly dispose of the old battery at your nearest hazardous waste collection site.

Battery Type: CR2430 Lithium Coin Cell



#### Warning for Australia:

Contains a button cell battery (also referred to as a coin cell battery), which is hazardous if swallowed – see instructions. The battery can cause severe or fatal injuries in 2 hours or less if swallowed or placed inside any part of the body.

If you suspect your child has ingested a button cell battery, call the Poisons Information Centre (24/7) immediately on 131126 from anywhere in Australia. Medical attention shall be sought immediately if it is suspected the battery has been swallowed or placed inside any part of the body.

Properly dispose of button cell batteries immediately in an outside bin, out of reach of children, and recycle them at your nearest hazardous waste collection site.

## 5. Miscellaneous

### 6.1 Disposal of equipment



Return old devices in accordance with the WEEE directive to suitable recycling facilities.

### 5.2 Conditions of use and storage

Environmental conditions: 0% up to max. 80%, not condensed

Storage temperature: -25 °C up to max. +70 °C

The devices have to be acclimatised to the specified temperature range (ta) before they can be operated.

### 5.3 Additional information

The Bluetooth® word mark and logos are registered trademarks owned by the Bluetooth SIG, Inc. and any use of such marks by Zumtobel Group AG is under license.

Tridonic GmbH & Co. KG is a subsidiary of Zumtobel Group AG.

Additional technical information at [www.tridonic.com](http://www.tridonic.com) → Technical Data

Guarantee conditions at [www.tridonic.com](http://www.tridonic.com) → Services

Lifetime declarations are informative and represent no warranty claim. No warranty if device was opened.