

sceneCOM S RTC CWM 31 BT NF DA2
sceneCOM S (single-channel)

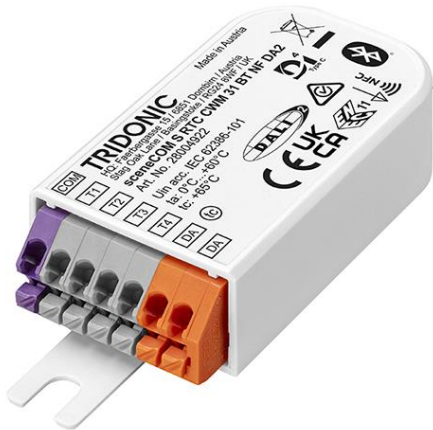

Product description

- _ DALI-2 Application Controller for management of small and mid-size room / area lighting installations, can be easily integrated into the wall socket behind the push button interface
- _ Ultra-compact dimensions and new housing with detachable mounting flaps enable use as a luminaire controller for stand-alone and networked applications
- _ Support for complete Tridonic control gear with DALI and DALI-2, as well as control gear certified by other manufacturers with DALI and DALI-2
- _ Future-proof thanks to simple firmware update via Bluetooth App (sCS commissioning)
- _ 4 independent inputs enabling connection of floating contact, standard momentary switches
- _ Power supply via DALI line
- _ 5 years guarantee (conditions at <https://www.tridonic.com/en/int/services/manufacturer-guarantee-conditions>)
- _ We will provide security updates for the next five years after the date of purchase of this product

Interfaces

- _ DALI line
- _ 4 independent inputs enabling connection of floating contact, standard momentary switches
- _ NFC ready to enable commissioning in production in the future
- _ Real Time Clock to share precise timing information in dynamic lighting and emergency applications ^①
- _ Wireless communications via Bluetooth
- _ Ready for future companionSUITE integration ^②

Functions

- _ DALI addressing
- _ DALI Grouping
- _ Sensor-based automation including presence/movement detection, daylight-linking
- _ Static and dynamic Tunable White applications
- _ Extendable with basicDIM Wireless
- _ Mobile commissioning and user App with intuitive user interface, available for Android and iOS
- _ adaptiveSWARM module support

^① Emergency application will be supported in future software releases. To be sure that the Emergency applications are supported, please read the release notes.

^② companionSUITE Integration will be implemented in the future.

Website

<http://www.tridonic.com/28004922>



sceneCOM S RTC CWM 31 BT NF DA2
sceneCOM S (single-channel)

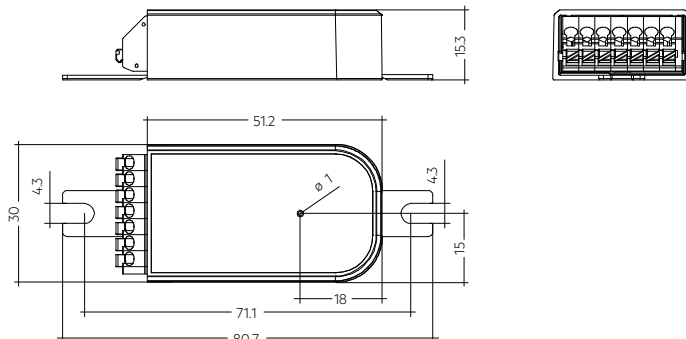

Ordering data

Type	Article number	Packaging, carton	Weight per pc.
sceneCOM S RTC CWM 31 BT NF DA2	28004922	18 pc(s).	0.018 kg
sceneCOM S RTC CWM 31 BT NF DA2 BP	28004930	30 pc(s).	0.018 kg

Technical data

Supply via	DALI cable
Supply voltage ^③	9,5 – 22,5 V
Current draw ^④	max. 30 mA
Bluetooth version	≥ 5.1
Bluetooth range	up to 20 m
Input	4 momentary-action switches or relays
Output	DALI
Ambient temperature t _a	0 ... +60 °C
t _c point	65 °C
Storage temperature t _s	-25 ... +60 °C
Humidity	20 ... 90 % not condensed
Starting time	≤ 6 s
Type of protection	IP20
Mounting	Mounting box 60 x 61 (ø x d)
Housing material	PC GWFI
Housing colour	White
Dimensions L x W x H	80,07 x 30 x 15,3 mm
Lifetime	up to 50,000 h
Guarantee (conditions at www.tridonic.com)	5 Year(s)

Approval marks



Standards

EN 61347-2-11, EN 61347-2-13, EN 61347-1, EN 300 328, EN 300 330, EN 301 489-1, EN 301 489-3, EN 301 489-17, EN 55015, EN 61547, EN 62479, EN 62493, EN 62311, EN 62386-101, EN 62386-103, EN 62386-301, EN 62386-351

^③ U_{in} acc. IEC 62386-101.

^④ Typical operational consumption average of 3.5 mA during steady operation.

1. Standards

EN 61347-2-11:2014
 EN 61347-2-13 / A1:2017
 EN 61347-1:2015
 EN 300 328 V2.1.1
 EN 300 330
 EN 301 489-1 V2.1.1
 EN 301 489-3 V2.1.1
 EN 301 489-17 V3.1.1
 EN 55015:2019 + A1:2020
 EN 61547:2009
 EN 62479:2010
 EN 62493:2015
 EN 62311:2020
 EN 62386-101 Ed.2
 EN 62386-103 Ed.1
 EN 62386-301
 EN 62386-351

1.1 DALI note



Device is developed as Multi-Master Application Controller according to DALI Standard EN 62386-101 Ed.2, also known as DALI-2.
 Device should not be used in combination with other application controllers.

1.2 Glow wire test

according to EN 61347-2-11 passed for temperatures up to 850°C.

1.3 Note system test

All components of the sceneCOM S system must be DALI-2 certified and listed on the DIIA web-page.
 sceneCOM S system was tested with Tridonic DALI-2 components only.
 Check compatibility yourself before installing, if Tridonic DALI-2 components are not used.

2. Common

2.1 Feature description

sceneCOM S RTC supports the full range of Tridonic DALI 2/D4i input devices as well as 3rd party input devices in case they are listed in DiiA database.

Static and Dynamic Tunable White applications make it possible to create, edit and store multiple dynamic lighting profiles in sCS Commissioning APP. 1 Dynamic lighting profile (lighting scene) is able to control multiple groups with TW luminaires .

Easy extension and integration with basicDIM Wireless devices via basicDIM Wireless DALI gateway is possible. basicDIM Wireless luminaires , sensors and push buttons can be visible and commissioned via sCS commissioning APP.

Mobile commissioning APP (sCS commissioning) with the intuitive user interface is available for Android and iOS.

Mobile User APP offers extensive user control possibilities for lighting installations and individual luminaires .

The physical Real Time Clock (RTC) on board complies with the strict emergency lighting standards in terms of accuracy and has an own independent battery.®

adaptiveSWARM module support is possible when sceneCOM S RTC works as an individual luminaire controller.

Support of IR6+ remote with the the possibility to adjust color temperature and advanced IR grouping possibilities. The new IR6+ remote, in combination with sceneCOM S RTC, is able to pair with up to 4 MSensors G3 individually. sceneCOM S RTC is the first Tridonic control device with NFC on board and is prepared for further integration with companionSUITE towards fully automated commissioning in OEM production.

There are two packaging options available, including single package focused on installers needs and bulk packaging (30 pcs) for lighting OEMs.

Bulk packaging was optimized for NFC commissioning.

With the sCS Commissioning APP it is possible to commission luminaires using new luminaire commissioning profile and import the floor plan as a picture.

For the device, companionSUITE integration is planned.

Together with the new sceneCOM S RTC Tridonic offers unic commissioning in production and testing workflow for Lighting OEMs, this workflow allows OEMs to commission luminaires in production using companionSUITE and BT interface.

2.2 Mobile sceneCOM S Remote User App

The Mobile User APP is available for iOS and Android smart devices and offers extensive user control possibilities for lighting installations and individual luminaires.

Android:



iOS:



3. Installation

- Device can be inserted into the mounting box for the momentary switch.
- Device must not be connected to the mains. It is supplied directly via the DALI signal line.
- The momentary switches are connected directly to the device (potential free contacts) and must not be connected to the mains.
- DALI signals are not SELV. Therefore the same procedures should be applied as working with mains voltage.
- Only one momentary switch for each device output.
- Only one application controller in the same DALI network allowed.
- Maximum range of the signal is up to 20 m. Avoid mount the device behind glass, concrete surfaces or in metal enclosures. If mounted behind such materials the signal range will be reduced.

3.1 Connection diagrams

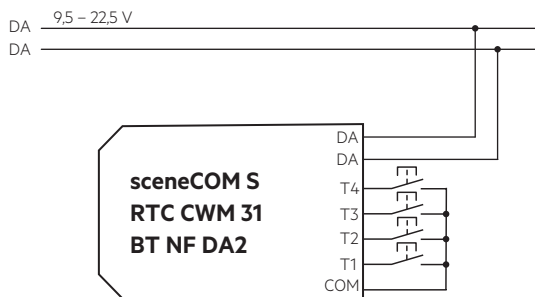
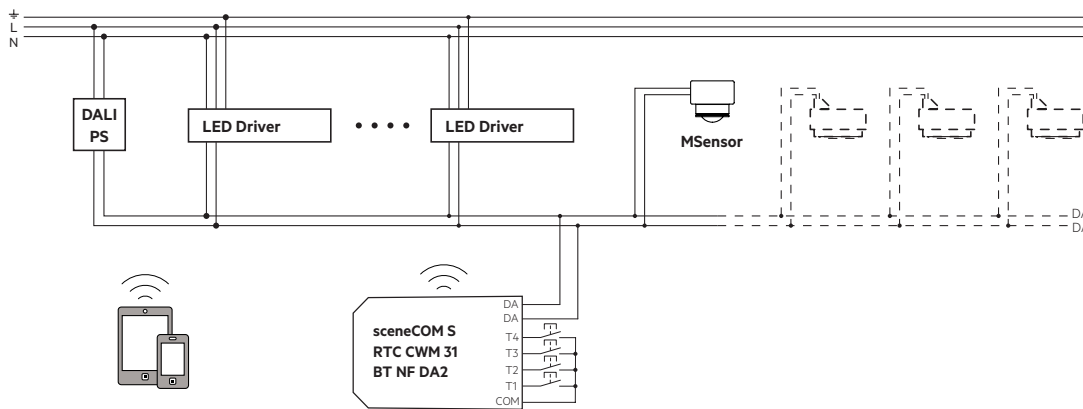

3.2 Wiring type and cross section

For wiring use stranded wire with ferrules or solid wire from 0.2 to 1.5 mm². Maximum cable length between momentary switch and sceneCOM S is 50 cm.

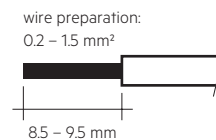

3.3 Terminals

- Orange = DALI D1 and D2
- Grey = Push button inputs T1 – T4
- Purple = Push button common

3.4 Mounting

Maximum range of the signal is up to 20 m.

Avoid mount the device behind glass or concrete surfaces and in metal enclosures.

If mounted behind such materials the signal range will be reduced.

3.5 Configuration

For commissioning and configuration the App „sCS commissioning“ (sceneCOM S) is provided by Tridonic. App can be installed on iOS and Android devices. Compatible with Android 11 / iOS 13 or later. Recommended to be used with devices with a screen size of 20 cm diagonal.

The device must support Bluetooth Low Energy version 5.1 or higher.

Android:



iOS:



3.6 Application Controller Features

The Application Controller is developed to be future safe. To achieve this the firmware can be updated via the commissioning app over the air.

Features like addressing, grouping, scenes are already implemented and can be used.

- Number of control gears = 64
- DT 1 Emergency Self-contained[®]
- DT 7 Switching relay
- TuWh, Device Type 8 (as specified in IEC-62386-209 Ed.1) fully supported
- Number of input devices in total = 16
- Max. 224 instances in total supported
- Number of groups = 16 according to DALI-2 Standard
- Number of scenes = 16 according to DALI-2 Standard

All Tridonic DALI-2 control devices e. g. MSensor G3 or DALI XC G3 are fully implemented and configurable.

As the application controller supports an easy way to update the firmware and develop new features an additional document with the extended release notes is available and can be downloaded from the Tridonic web page.

3.7 Nearfield communication (NFC)

The NFC Interface allows wireless communication with the device.

This interface offers the option to write and read configuration with the companionSUITE as soon it is integrated.

A correct communication between the device and the NFC antenna can only be guaranteed if the antenna is placed directly on the device.

Any material placed between the device and the NFC antenna can cause a deterioration of the communication quality.

After programming the device via NFC power up the device one time for one second till the deviceANALYSER can read out the parameters.

We recommend the use of following NFC antenna:

www.tridonic.com/nfc-readers

NFC is complied with ISO/IEC 15963 standard.

3.8 Description BP Version

The Products sceneCOM S RTC CWM 31 BT NF DA2 (28004922) and sceneCOM S RTC CWM 31 BT NF DA2 BP (28004930) are technically the same.

The difference is in the packaging. The BP (Bulk Package) version is meant for Production lines where multiple Products can be programmed simultaneously via NFC in this package the Products are packed as Bulk and not in Single packaging. In the non-BP version, on the other hand, each product is also individually packaged.

3.8.1 Correct placement of the cardboard on the NFC antenna

It must be ensured that the cardboard is placed in the center of the antenna and does not protrude beyond it.

The cardboard must be placed so that the arrows on the cardboard point in the direction of the antenna.

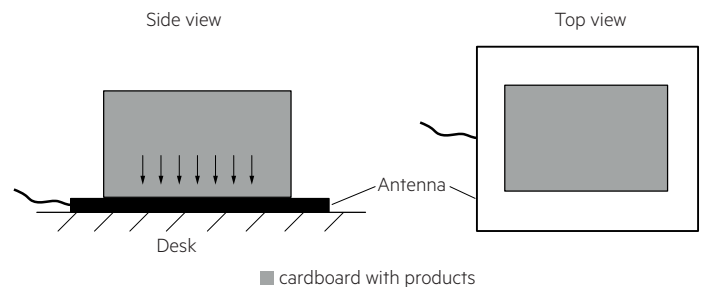

3.9 Placement

Device has an integrated antenna. Certain materials can reduce the range of the antenna. During assembly, the following should be observed.

The antenna is located at the corner of the case, at the bottom of the PCB, just above the bottom of the device. By placing the antenna at this point, the influence of other components on the antenna performance is minimized.

In addition, the device should be placed as far away as possible from metal structures.

Wires of the device should not lead past the antenna.

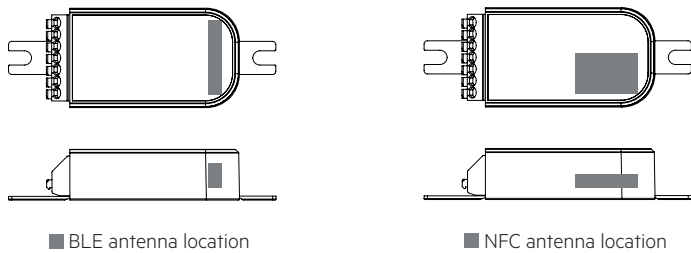

3.10 Status LED

Device is equipped with an multi color LED placed behind the label. Depending on colour and flashing pattern different status information are provided.

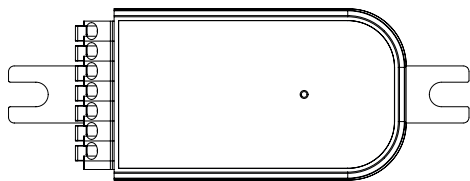

Status LED	Indicates
Blue blinking	Bluetooth connection active
Red blinking	At least one input closed

3.11 RTC Clock parameters

Time drift	
Seconds / week	± 35
Minutes / Year	± 15

3.12 RTC backup time

The RTC keeps the time for up to 10 days if the sCS was powered for at least 24 h. Then the internal backup battery is fully charged. If your sCS is disconnected from the DALI power supply during that time frame, the RTC will still work. In case of prolonged disconnection, connect the sCS with your mobile device to re-establish time synchronization.

Depending on the environment, time can also get out of synchronization earlier.

During usage of the RTC feature it is recommended to always keep the sCS powered, or keep the duration where power supply is cut as short as possible.

4. Miscellaneous

4.1 Disposal of equipment



Return old devices in accordance with the WEEE directive to suitable recycling facilities.

4.2 Additional information

Additional technical information at www.tridonic.com → Technical Data

Guarantee conditions at www.tridonic.com → Services

Lifetime declarations are informative and represent no warranty claim. No warranty if device was opened.