

**basicDIM ILD G2 4DPI WDA**

Compact control module with ambient light sensor and motion sensor



basicDIM ILD G2 SFI 20 4DPI WDA WH



basicDIM ILD G2 SSM 20 4DPI WDA WH



basicDIM ILD G2 SRC 20 4DPI WDA WH

**Product description**

- \_ For up to 64 DALI drivers, expandable with DALI-2 Input Devices (see data sheet 3.1 Wiring)
- \_ Wide detection angle of up to 125° covering an area of up to 141 m<sup>2</sup>
- \_ Integrated application controller
- \_ Flexible configuration via companionSUITE
- \_ 2 DALI groups with adjustable offset
- \_ Monitoring of ambient light and motion detection
- \_ Infrared remote control for configuration and operation
- \_ Power supply via DALI line
- \_ Shutter for preventing occupancy detection in one direction included
- \_ Small dimensions allowing easy and inconspicuous integration in luminaires
- \_ For luminaires of protection class II
- \_ Wide range of accessories allowing extended application range
- \_ 5 years guarantee (conditions at <https://www.tridonic.com/manufacturer-guarantee-conditions>)

**Housing properties**

- \_ Casing: polycarbonate, white
- \_ Type of protection up to IP54

**Website**

<http://www.tridonic.com/28004639>





**Technical data**

Sensor type	PIR sensor
Supply via	DALI cable
Supply voltage <sup>①</sup>	11,5 – 20,5 V
Current draw	6 mA from DALI
Current consumption (no LED)	max. 11 mA
Current consumption (with LED)	max. 12 mA
Mounting height	2 – 4 m
Mounting hole diameter <sup>②</sup>	23 mm
Housing thickness of the luminaire	0,75 – 4 mm
Detection angle for PIR detection <sup>③</sup>	125°
Detection angle for light measurement <sup>④</sup>	80° – 150°
Detection range for light measurement <sup>⑤</sup>	2 – 2,000 lx
Min. temperature difference between ambient temperature and detected object	± 4 °C
Ambient temperature $t_a$	-20 ... +50 °C
$t_c$ point	60 °C
Storage temperature $t_s$	-25 ... +60 °C
Housing material body	PC polycarbonate
Housing material lens	PE polyethylene
Housing colour body	White (similar to RAL 9010)
Housing colour lens	White
Type of protection <sup>⑥</sup>	Up to IP54
Guarantee (conditions at <a href="http://www.tridonic.com">www.tridonic.com</a> )	5 Year(s)

**Approval marks****Standards**

EN 61347-2-11, EN 55015, EN 61000-3-2, EN 61000-3-3, EN 61547, EN 62386-101, EN 62386-103, EN 62386-301, EN 62386-303, EN 62386-304

① 14 – 20,5 V if use PB11. Uin according to IEC 62386-101.

② This value is only valid for SFI version. For SRC version the mounting hole diameter is 55 to 57 mm.

③ For details see chapter detection area in data sheet.

④ For details see chapter light measurement in data sheet.

⑤ The measured value at the sensor head corresponds to approx. 10 to 10,000 lux on the surface measured.

⑥ Depending on the installation type up to IP54 for more details see chapter 3.7.

## Sensor mounting kit ACU 033 IP66 WH

Accessory

**Product description**

- \_ Easy to mount circlip locking, compatible with industry standard circlip pliers (size 19 – 60 mm)
- \_ Corrosion resistant circlip made from stainless steel
- \_ Appealing plastic cover ring, allowing to mount the sensor in luminaires in an easy and visual attractive way
- \_ Fulfills the impact energy requirements of freestanding luminaires of 0.5 J
- \_ Includes 2 gaskets offering flexible installation in luminaires
- \_ Plastic cover passed glow wire test with 750 °C in according to EN 61347-1
- \_ In combination with the DALI MSensor G3 SFI 30 PIR 4DPI WDA WH, a maximum of IP54 is possible
- \_ In combination with the basicDIM ILD G2 4DPI WDA, a maximum of IP54 is possible

**Website**

<http://www.tridonic.com/28004207>

**Ordering data**

Type	Article number	Packaging, carton	Weight per pc.
Sensor mounting kit ACU 033 IP66 WH	28004207	20 pc(s).	0.006 kg

## Sensor mounting kit ACU 030 IP66 WH

Accessory

**Product description**

- \_ Mounting ring allowing to mount the sensor into a luminaire in easy and visual attractive way
- \_ Including three different gaskets 3, 5 and 8 mm
- \_ For more details see data sheet chapter 3.5 (mounting ring) and 3.6 (gasket)
- \_ Mounting ring passed glow wire test with 750 °C according to EN 61347-1
- \_ In combination with the DALI MSensor G3 SFI 30 PIR 4DPI WDA WH, a maximum of IP54 is possible

**Website**

<http://www.tridonic.com/28002459>

**Ordering data**

Type	Article number	Packaging, carton	Weight per pc.
Sensor mounting kit ACU 030 IP66 WH	28002459	20 pc(s).	0.006 kg

REMOTECONTROL IR6

Accessory



**Product description**

- \_ Optional infra-red remote control
- \_ Switching on and off (On/Off button)
- \_ Dimming (Up/Down button)
- \_ Activation of automatic lighting control (Automatic button)
- \_ Setting the threshold control point (Set button)
- \_ IR range up to 20 m

**Website**

<http://www.tridonic.com/28000647>



**Ordering data**

Type	Article number	Dimensions L x W x H	Packaging, carton	Weight per pc.
REMOTECONTROL IR6	28000647	86.5 x 40.5 x 7.2 mm	500 pc(s).	0.019 kg

basicDIM ILD G2 Programmer

Accessory



**Product description**

- \_ Optional infra-red programming unit for basicDIM ILD G2
- \_ Setting of predefined parameter values
- \_ Programmable functions such as light level, time delay, P.I.R., bright-out, power up and grouping
- \_ IR range up to 20 m

**Website**

<http://www.tridonic.com/28003484>

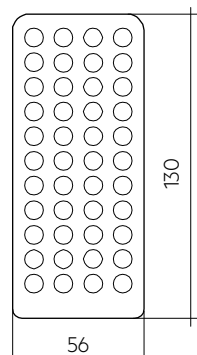

**Ordering data**

Type	Article number	Packaging, carton	Weight per pc.
basicDIM ILD G2 PROGRAMMER	28003484	150 pc(s).	0.04 kg

**Approval marks**



**DALI XC G3 CWM 30 DA2**

**Accessory**



**Product description**

- \_ DALI-2 input controller
- \_ Compatible with DALI-2 certified Application Controller
- \_ Suitable only for DALI-2 certified or compatible lighting control systems, not compatible with Tridonic's comfortDIM system
- \_ 4 independent inputs enabling connection of floating contact, standard momentary switches
- \_ Multiple DALI XCs possible on the DALI-2 line
- \_ Power supply via DALI-2 line
- \_ Connection wires according to the terminal colours with 25 cm length included
- \_ 5 years guarantee (Conditions at <https://www.tridonic.com/manufacture-guarantee-conditions>)

**Website**

<http://www.tridonic.com/28002877>

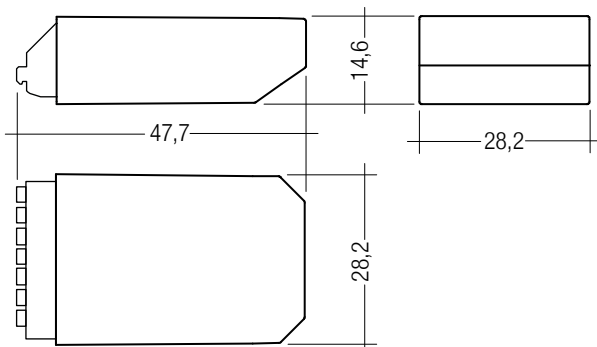

**Ordering data**

Type	Article number	Packaging, carton	Weight per pc.
DALI XC G3 CWM 30 DA2	28002877	60 pc(s).	0.087 kg

**Approval marks**



**basicDIM ILD G2 CWM 20 PBI1**

Accessory

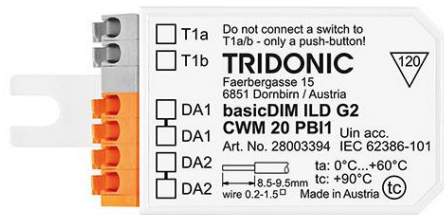

**Product description**

- \_ Push Button Interface (PBI) for ILD G2 and ILD G2 FSL system
- \_ Flexible configuration via the ILD G2 and ILD G2 FSL in combination with the companionSUITE
- \_ Short push button action: automatic / fade off (factory default)
- \_ Long push button action: dim up / dim down (factory default)
- \_ Double push button action: set new target value for light regulation (factory default)
- \_ Through-wiring DA1 / DA2 possible
- \_ Detachable mounting flaps, allow installation in flush-mounted boxes and luminaires

**Note**

- \_ A permanent short circuit between T1a and T1b results in limited function
- \_ Only push buttons can be used

**Website**

<http://www.tridonic.com/28003394>

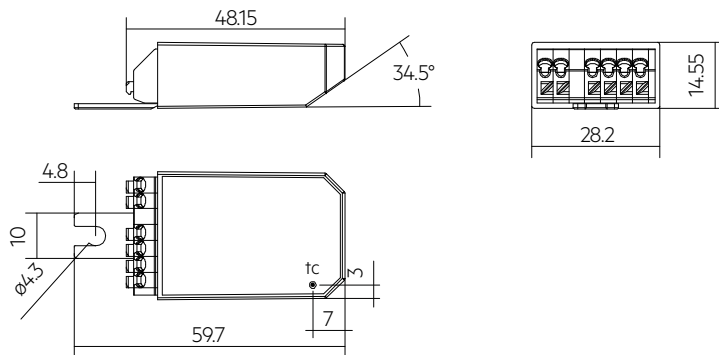

**Ordering data**

Type	Article number	Packaging, carton	Weight per pc.
basicDIM ILD G2 CWM 20 PBI1	28003394	15 pc(s).	0.012 kg

**Approval marks**



Shading Set 4DPI WDA

Accessory

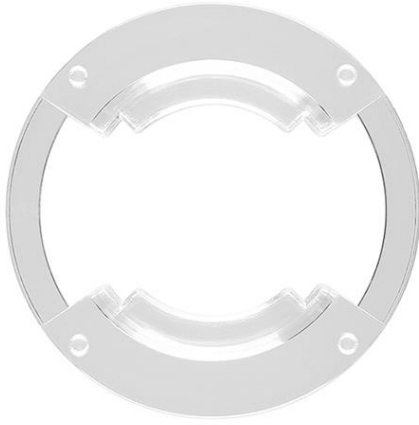

Corridor



90° shutter



180° shutter

**Product description**

- \_ Shading set consisting of 3 different types of lenses: Corridor, 90° and 180° shutter
- \_ Shutters mountable directly to the front of the sensor in 4 different positions 0°, 90°, 180° and 270° angle relative to the sensor device
- \_ No disturbance of light measurement or IR receiver signals
- \_ Material transparent Lexan 923 with polished surface finish
- \_ Shutters made for one time use, once installed removal may damage the shutter and sensor lens!

**Website**

<http://www.tridonic.com/28003867>



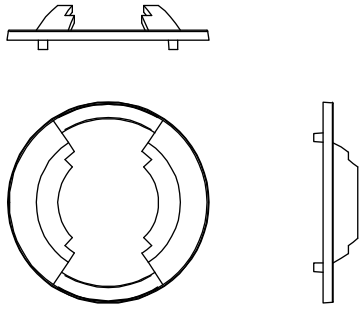

Corridor

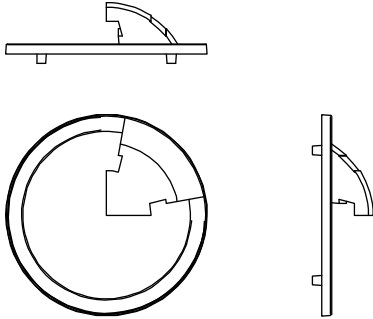

90° shutter

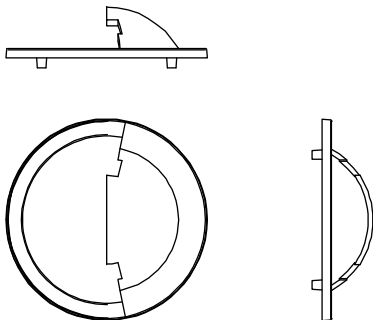

180° shutter

**Ordering data**

Type	Article number	Packaging, carton	Weight per pc.
ACU SHADING SET 034 4DPI WDA	28003867	20 pc(s).	0.001 kg

## 1. Standards

EN/IEC 61347-2-11  
 EN 55015  
 EN 61000-3-2  
 EN 61000-3-3  
 EN 61547  
 EN 62386-101  
 EN 62386-103  
 EN 62386-301  
 EN 62386-303  
 EN 62386-304

### 1.1 DALI standard

The basicDIM ILD G2 WDA is designed to control control gear with DALI standard IEC 60929 (DALI VO), IEC 62386 (DALI V1/DALI-2).

### 1.2 Glow wire test

according to EN 61347-2-11 passed for temperatures up to 850°C.

## 2. Common

The basicDIM ILD G2 WDA provides the basis for an easy-to-use and cost-effective lighting system with motion detection.

With this Sensor, the customer gets a small sized sensor for low height applications and a protection against environmental influence up to IP54.

This sensor provides measurement of ambient light, occupancy detection via PIR sensor and IR remote control input as well as a LED output for signalisation.

This sensor provides measurement of ambient light, motion detection via PIR sensor and IR remote control input as well as a LED output for signalisation.

basicDIM ILD G2 WDA is created for following main applications:

Low height buildings such as

- Office applications
- Factory buildings
- Storage buildings and warehouses
- Corridors, passages and Garages



The basicDIM ILD G2 WDA was developed and tested exclusively for Tridonic MSensor G3, MSensor G3 WDA, XC G3 and PBI1. The use of other sensors and push button modules can lead to errors.



Do not use the basicDIM PBI in installations where the DALI wiring is longer than 80 m.

## 3. Installation

- Do not connect the basicDIM ILD G2 WDA to the mains. The power is supplied directly via the DALI line.
- DALI is not SELV. The installation instructions for mains voltage therefore apply.
- The detection range of the sensor must be within the lighting area of the controlled luminaires.
- The detection ranges of the sensors must not overlap, as this will affect the light control.
- To avoid deviating characteristics, install the presence detector at the recommended height. If the installation is higher than recommended, the sensitivity is reduced. If the installation is lower than recommended, the detection range is reduced.
- Incorrect presence detection occurs if heaters, fans, printers or copiers are in the detection area.
- Avoid direct illumination of the light source (luminaires) on the sensor including housing.
- Additional IR sources can interfere with the sensor.
- The maximum permissible current consumption of all components on the bus must not exceed the maximum permissible current of the connected DALI Power Supply.
- When using pre-addressed DALI components, double addressing may occur. This error can be corrected by pressing the reset button (basicDIM ILD G2 programmer). The commissioning must be carried out again.
- Shutters are for single use only. Removal will damage the shutter and the sensor lens. Please note this before using the shutters!
- Do not use aggressive cleaning detergents to clean the sensor lens, for example. The cleaning detergents must not harm the sensor materials. Please note this before using the cleaning detergents!

3.1 Wiring

Room application:

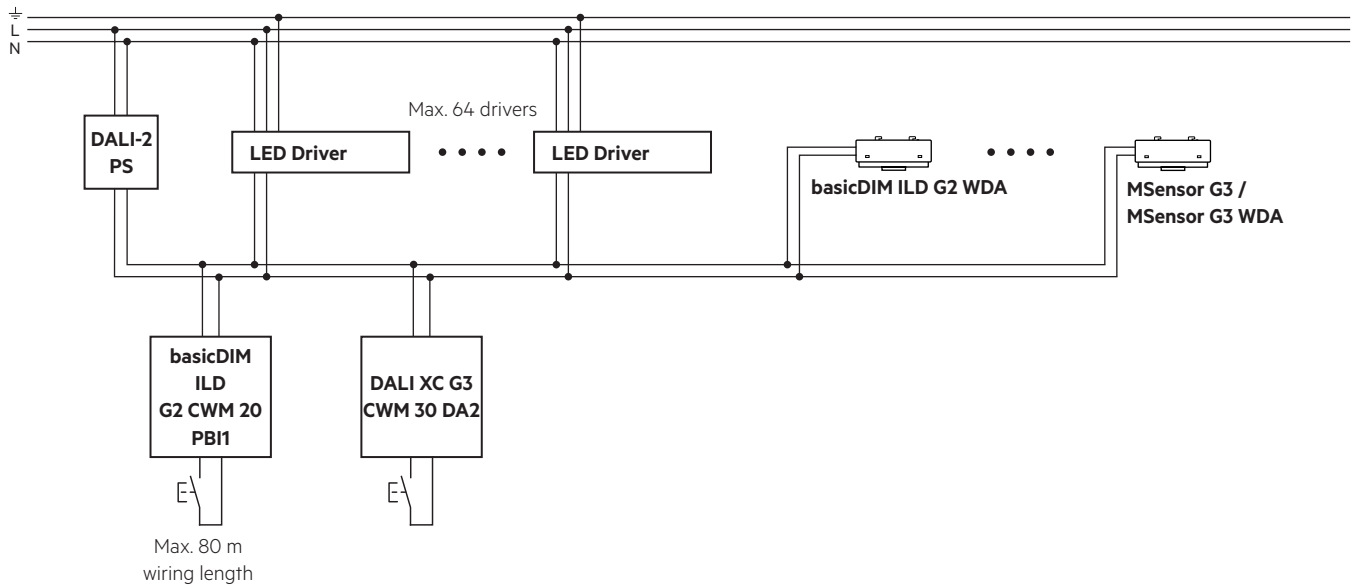

Single / free-standing luminaires, driver with integrated power supply (DALI):

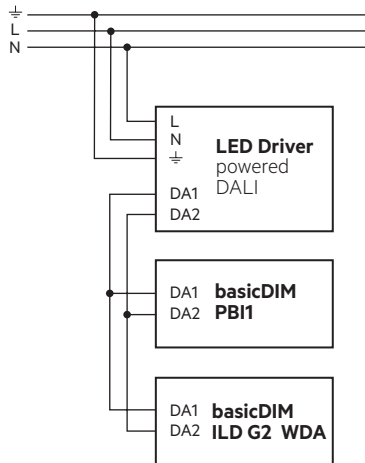

Single / free-standing luminaires, driver with separate power supply (DALI):

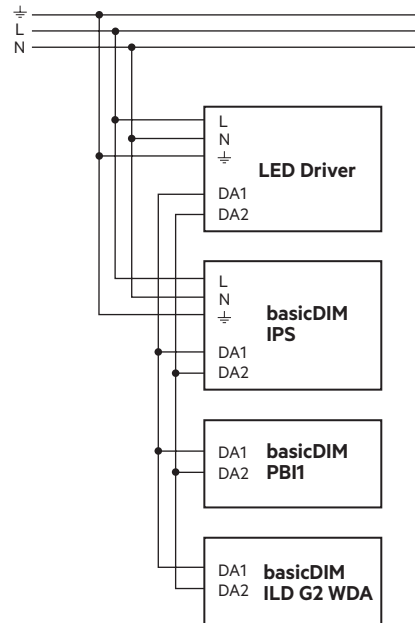

Maximum number of connected devices:

Devices	Number
basicDIM ILD G2 WDA	1 pc.
DALI PS	1 pc. (max. 250 mA)
LED driver	64 pcs.
Input devices (MSensor G3, XC G3)	8 pcs.
PBI1	4 pcs.

DALI repeater must not be used.

**!** Do not use the basicDIM PBI in installations where the DALI wiring is longer than 80 m.  
If more than 80 m use DALI XC G3 only.

Compatible accessories:

- MSensor G3 and MSensor G3 WDA as additional, slave motion detector
- XC G3 as multi channel push button interface

Factory settings for DALI XC G3:

Button	Action	Factory settings
T1	Short press	Automatic / Fade off
	Long press	Dim up / Dim down
	Double click	SET (store new value for constant light control)
T2	Short press	Automatic
	Long press	not used
	Double click	not used
T3	Short press	not used
	Long press	Dim up / Dim down
	Double click	not used
T4	Short press	Automatic (switch luminaire on or change to automatic mode)
	Long press	not used
	Double click	SET (store new value for constant light control)

### 3.2 Wiring type and cross section

#### SFI version:

For wiring use stranded wire with ferrules from 0.2 to 0.5 mm<sup>2</sup> or solid wire from 0.14 to 0.5 mm<sup>2</sup>.

0.14 – 0.5 mm<sup>2</sup> solid or  
0.2 – 0.5 mm<sup>2</sup> stranded wire

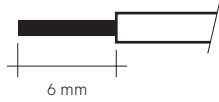

#### SRC version:

For wiring use stranded wire with ferrules or solid wire from 0.5–1.5 mm<sup>2</sup>. Strip 9 mm of insulation from the cables to ensure perfect operation of the push terminals.

Use one wire for each terminal connector only.  
Use the strain relief for one cable only.

#### SSM version:

For wiring use solid wire from 0.5–1.5 mm<sup>2</sup>. Strip 9 mm of insulation from the cables to ensure perfect operation of the push terminals.  
Use one wire for each terminal connector only.

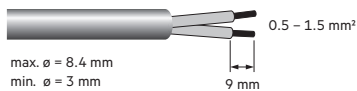

### 3.3 Mounting variants luminaire installation sensor:

#### 3.3.1 Installation in luminaire

To ensure the right IP protection please read chapter 3.6 Gasket.

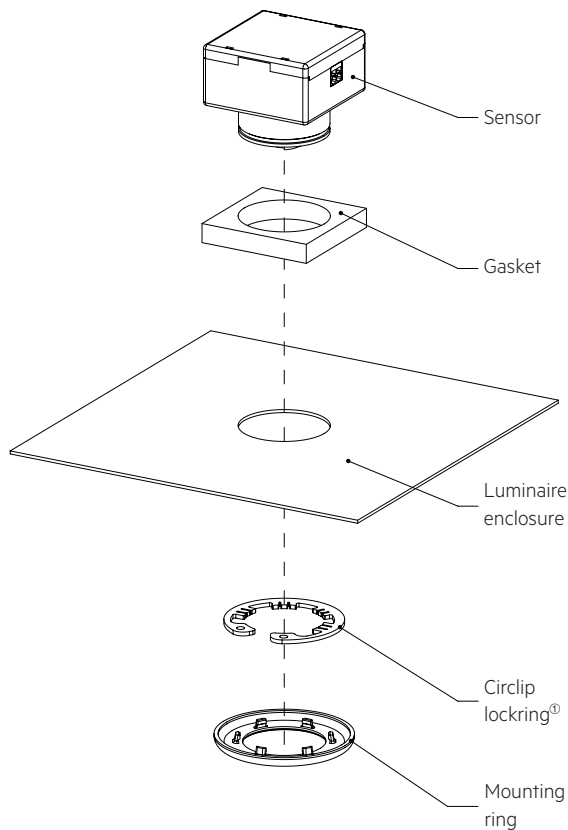

<sup>1</sup> Not included in kit ACU 030.

### 3.4 Detection area covers

Included in each ACU SHADING SET 034 4DPI WDA there are 3 detection area covers included.

Type of material: Lexan 923  
 Colour: transparent  
 Surface finish: polished

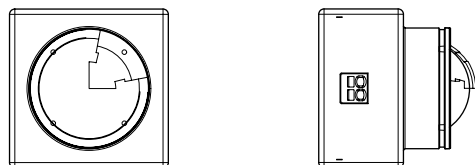

Attach the detection area cover to the sensor by inserting it into the corresponding groove at the front of the sensor.

Shutters made for one time use, once installed removal may damage the shutter and sensor lens!

If you install a damaged shutter to the sensor the risk is high that the shutter falls off!

Area which is masked by the shutter:

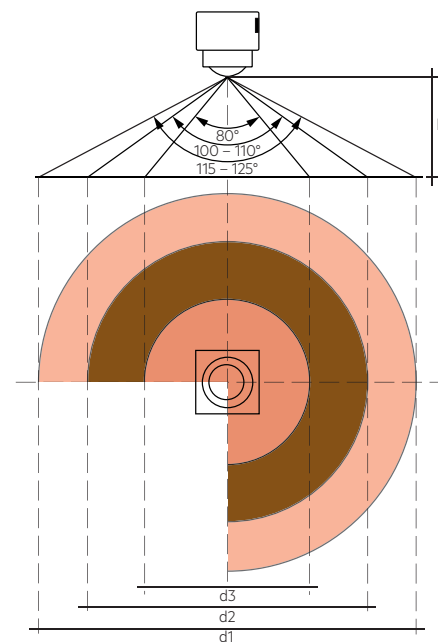
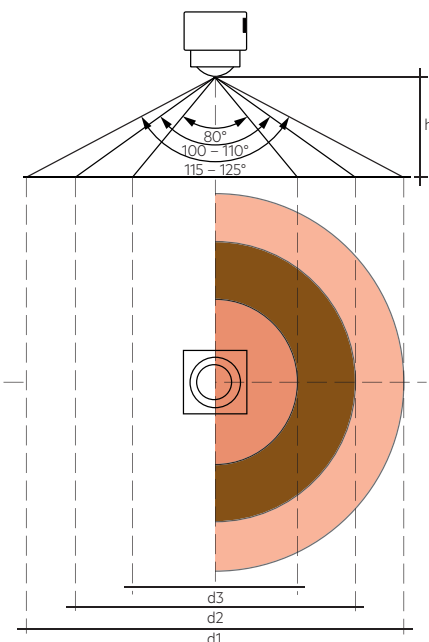
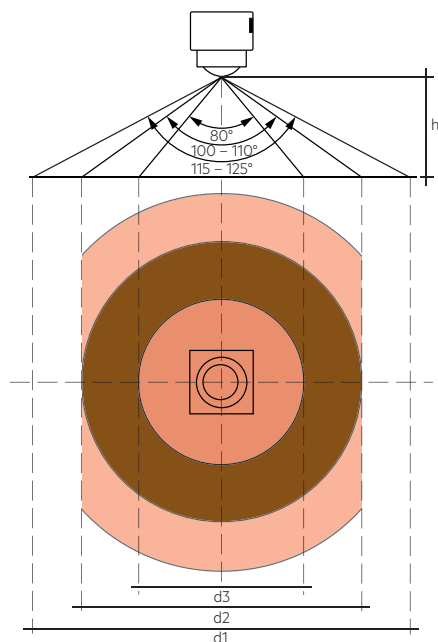
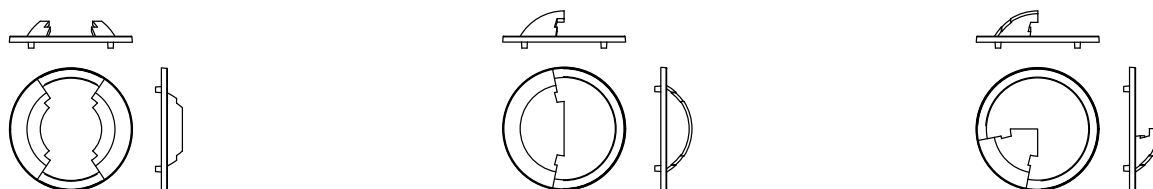

### 3.5 Mounting ring

Included in each Sensor mounting kit ACU 030 IP66 WH and kit ACU 033 IP66 WH is a mounting ring. This ring allows to mount the sensor into a luminaire in an easy and visual attractive way.

3,7 for ACU 030  
 3 for ACU 033

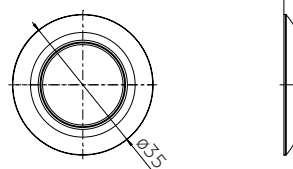

### 3.6 Gasket

To fulfill ingress protection different gaskets are included in the Mounting Kit. The gaskets are necessary to ensure ingress protection as well as proper mounting of the sensor in luminaire.

Sensor can be inserted into luminaires with a cover size from 0.75 up to 4.0 mm.

According to the size of luminaire cover in certain application, one of the gaskets must be used and mounted between the front of the sensor and the luminaire housing. It is not allowed to use a combination of e.g. two gaskets, because this will not provide the right amount of sealing and you may run in to a risk to not reach the IP54 requirements.



Use maximum possible size for your application to ensure a proper fit and protection.

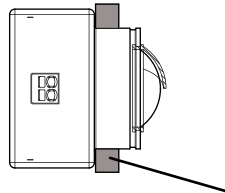

Gasket (size 3, 5 or 8 mm)

#### Sensor mounting kit ACU 030 IP66 WH

Distance between Sensor and luminaire	Final size of gasket after assembly	Use gasket
2.0 – 2.4 mm	2.0 – 2.4 mm	3 mm
2.5 – 4.0 mm	2.5 – 4.0 mm	5 mm
4.0 – 5.9 mm	4.0 – 5.9 mm	8 mm

#### Sensor mounting kit ACU 033 IP66 WH

Distance between Sensor and luminaire	Final size of gasket after assembly	Use gasket
2.7 – 4.0 mm	2.7 – 4.0 mm	5 mm
4.0 – 5.9 mm	4.0 – 5.9 mm	8 mm

### 3.7 Ingress protection

This device contains IP-protection to use it also in applications with the need of protection against dust and water ingress. IP54 protection applies to the front of the sensor whereas the back of the sensor is IP20 rated.

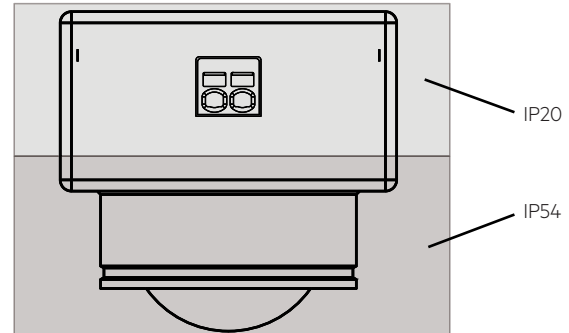

Only valide for SFI version.  
SSM and SRC version are only IP20 protected.

### 3.8 Mounting in class II luminaire

The Sensor provides basic insulation as required by IEC 62386-101 and defined in IEC 61347-1.

If the sensor is built in to a class II luminaire which has to provide double or reinforced insulation it has to be considered that the Sensor is not a class II device. Still the Sensor can be used for such projects as the most part of the sensor is tested to fulfil the class II requirements for double or reinforced insulation. Basic insulation is illustrated in the graphic below and covers an area 2,5 mm around the terminal.

The rest of the sensor fulfils class II requirements.

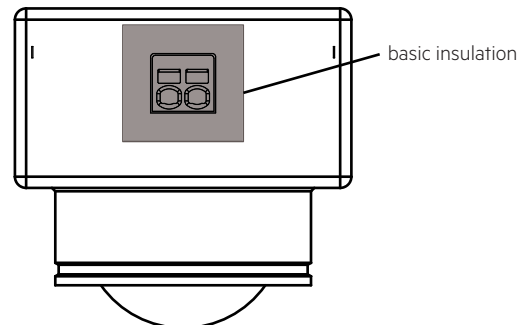

#### 4. Sensor function

##### 4.1 Occupancy / motion detection

For occupancy detection PIR technology is used. The PIR Lens is made to detect moving people in areas such as office, open space or corridors with the following performance criteria:

- Ceiling height from 2 up to 4 m
- Movement of human body
- Center area with increased sensitivity to detect small movements with speed  $\geq 0.5$  m/s for mounting heights up to 3 m (80° full angle)
- Movement speed  $\geq 1.0$  m/s for mounting heights up to 4 m



Reaction time of the sensor (time between occupancy detected and event information send to DALI Bus) is  $\leq 25$  ms.

The reaction time of the system can be extended by factors such as the amount of data on the bus, the number of connected devices or the control device used (Application Controller).

The point at which the light responds must therefore not be equated with the outer detection range.

##### 4.2 Detection area

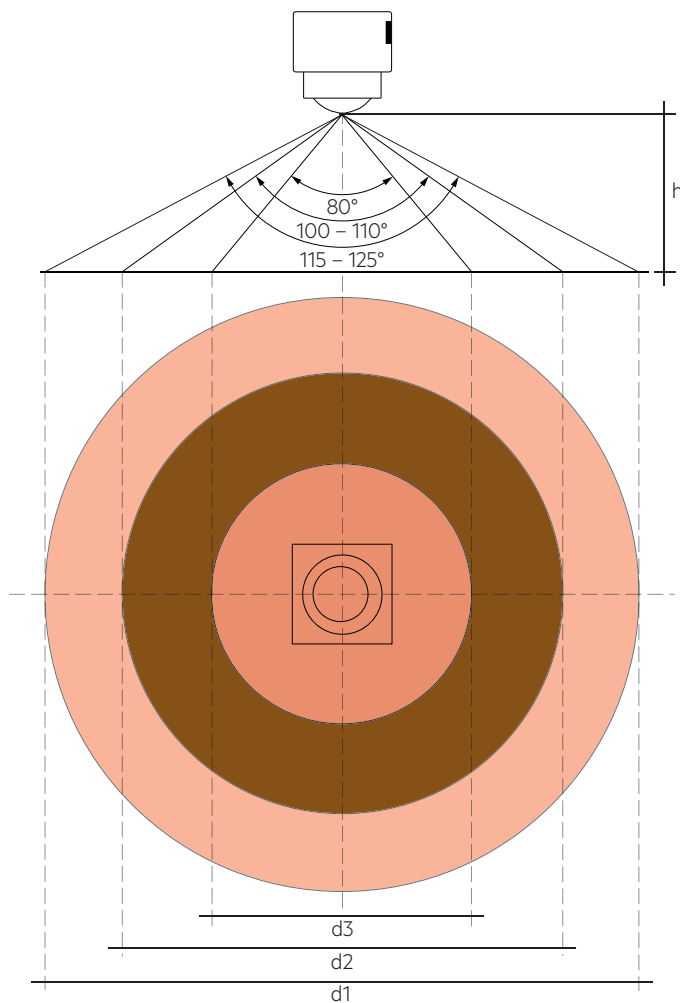

h = Height	d1 = Tangential movements		d2 = Radial movements		d3 = Small movements	
	Full angle	Diameter	Full angle	Diameter	Full angle	Diameter
2.0 m	125°	7.7 m	110°	5.7 m	80°	3.4 m
2.5 m	125°	9.6 m	110°	7.1 m	80°	4.2 m
3.0 m	125°	11.5 m	110°	8.6 m	80°	5.0 m
3.5 m	125°	13.4 m	110°	10.0 m	-	-
4.0 m	115°	12.6 m	100°	9.5 m	-	-

Schematic illustration of radial / tangential movements:

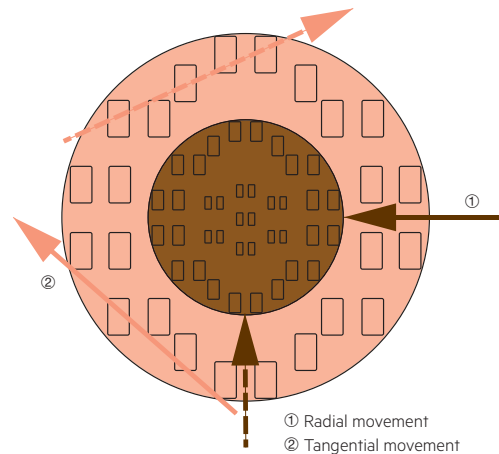

Detection example at 2.5 m mounting height:

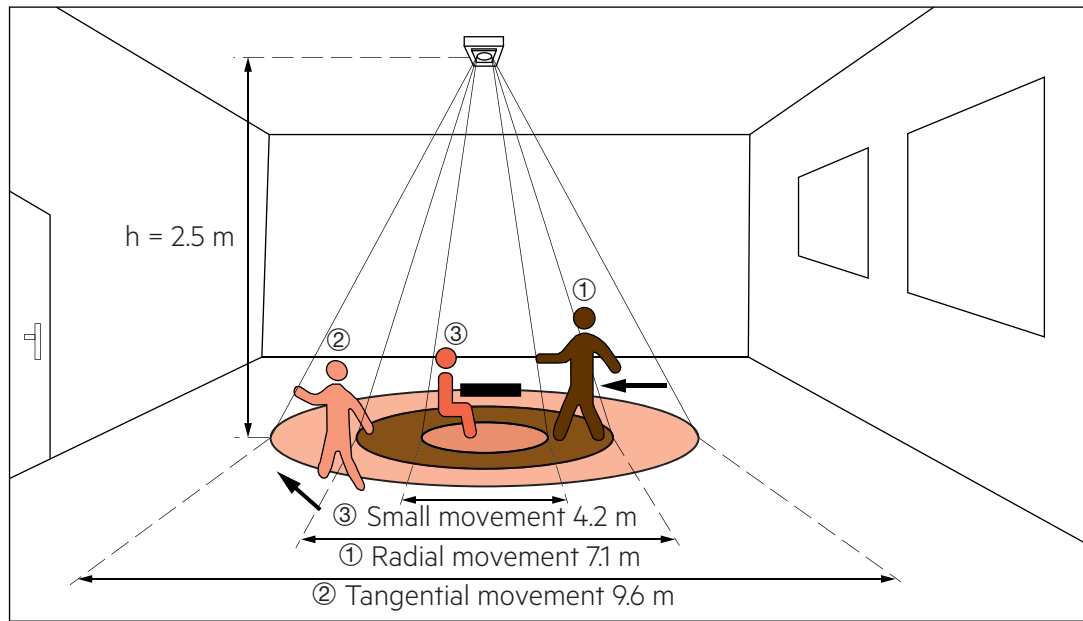

### 4.3 Light measurement

The light measurement has a cone-shaped detection area with a half angle of approximately 75° in x-direction and 40° in y-direction.

Pay attention on the position of the sensor!

The detection area is asymmetrical and the position of the sensor makes a difference which area reflection is used for the light measurement.

The terminal of the sensor is visualized in the graphic and can be used for orientation of the direction.

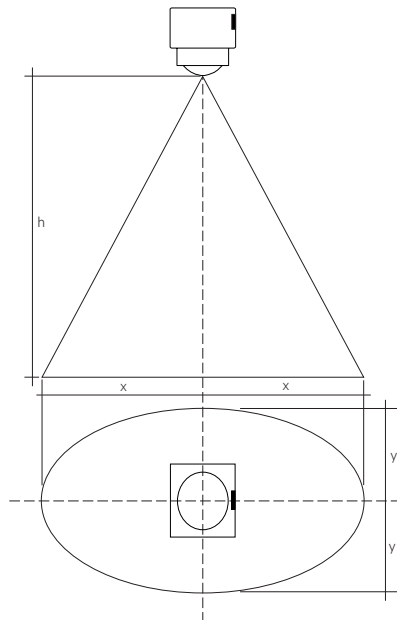

h	dx	dy
2 m	3.0 m	1.5 m
3 m	4.6 m	2.2 m
4 m	6.1 m	2.9 m

### 4.4 Status LED's

The status LED is deactivated by default.

There is a LED built in to indicate different status information to the user.

This LED is controlled from the sensor itself.



To not have any influence from LED to the light measurement, LED is disabled while light sensor is measuring by default.

Status	Pattern	Incident
-	-	Normal operation
Single red flash	0.2 s on. all 6 s	Motion has been detected
Permanent red flashing	0.2 s on. all 1 s	System error: - Second basicDIM ILD G2 WDA available - Stuck button time out
Long green flashing	1 s on. all 6 s	Bright-out active
Orange flashing	0.5 s on. all 0.5 s	Start-up, Grouping, Test mode, Reset active
Short blue flashing	0.2 s	Receive infrared command from basicDIM ILD G2 Programmer or IR6

The measurement range is between 0.5 and 2000 lx.

Measured at the sensor head.



To be able to measure values < 5 lx in an accurate way it is needed to change integration time of light sensor to 800 ms. Integration time of light sensor is set to 100 ms by default. For values > 5 lx there is no difference in between these measurements.

## 4.5 User-definable parameters

Parameter	Range (Factory Settings)	Description
power-up behavior	on / off (on)	If the parameter is set to "on", the luminaire switches on after a mains break. If the parameter is set to "off", the luminaire does not switch on after a mains break.
presence level	1 to 100 % (100 %)	Brightness value that the ILD G2 occupies as soon as presence has been detected.
absence level	1 to 100 % (1 %)	Brightness value that the ILD G2 occupies while the switch-off delay is running.
fade-in time	0 to 15 (1)	Period of time starting as soon as presence is detected. During fade-in time, the luminous intensity fades to the presence value. 1 = 0.7 s   2 = 1 s   3 = 1.4 s   4 = 2 s   5 = 2.8 s   6 = 4 s   7 = 5.7 s   8 = 8 s   9 = 11.3 s   10 = 16 s   11 = 22.6 s   12 = 32 s   13 = 45.3 s   14 = 64 s   15 = 90.5 s
fade time	0 to 15 (8)	Period of time during which the luminous intensity fades from the presence value to the absence value. 1 = 0.7 s   2 = 1 s   3 = 1.4 s   4 = 2 s   5 = 2.8 s   6 = 4 s   7 = 5.7 s   8 = 8 s   9 = 11.3 s   10 = 16 s   11 = 22.6 s   12 = 32 s   13 = 45.3 s   14 = 64 s   15 = 90.5 s
run-on time	15 s to 60 min (20 min)	Time that begins to run from the last moment that presence was detected. After the run-on time the fade-off time is started. If another presence is detected in the room during run-on time, the run-on time is started again.
switch-off delay	off / 15 s to 60 min / never OFF (off)	Time in which the absence value is held. After expiration, the luminaire is either switched off or the absence value is held (never OFF).
fade-off time	0 to 15 (2)	Period of time starting after the run-on time. During the fade-off time, the luminous intensity fades to off. 1 = 0.7 s   2 = 1 s   3 = 1.4 s   4 = 2 s   5 = 2.8 s   6 = 4 s   7 = 5.7 s   8 = 8 s   9 = 11.3 s   10 = 16 s   11 = 22.6 s   12 = 32 s   13 = 45.3 s   14 = 64 s   15 = 90.5 s
constant light control	on / off (on)	Enables or disables the constant light control
bright-out	on / off (on)	If the parameter is set to "on", the luminaire switches off as soon as the light level exceeds the bright-out threshold of the set point for longer than 10 minutes. This could be the case if, for instance, the room is adequately illuminated by sunlight. If the bright-out threshold falls below 100 % of the set point, the luminaire switches back on again.
bright-out threshold	110 to 400 % (150 %)	Bright-out threshold used by the bright-out function
bright-out-off delay time	0 to 3,600 s (600 s)	Period of time that the light level must exceed the bright-out threshold to activate bright-out.
group 2 offset mode	fixed / converging (converging)	This parameter specifies how the group 2 offset value behaves if the light is dimmed up. If the parameter is set to "converging", the dimming level of group 2 will keep on rising even if group 1 has already reached a dimming level of 100 %. The brightness difference will be gradually reduced up to the point where both group 1 and group 2 reach the same dimming level of 100 % which effectively reduces the group 2 offset value to zero. This way, the offset will "converge". If the parameter is set to "fixed", the offset is "fixed". The brightness difference between group 1 and group 2 will stay at the value defined for the group 2 offset value. If the group 2 offset value was set to e.g. 30 %, the group 2 dimming level will always stay 30 % below the dimming level of group 1. If group 1 has reached a dimming level of 100 %, the dimming level of group 2 will stop rising because otherwise the offset would be reduced to less than the defined group 2 offset value.
group 2 offset value	0 to 95 % (30 %)	Adjustable brightness difference between group 2 and group 1

#### 4.6 Possible push button configuration

Short Press	Long Press	Double Press
Automatic mode	Dimming up	Set target value
Recall max. level	Dimming down	No function
Off	Dimming up / dimming down	
Recall max. level / off	No function	
On with fade		
Off with fade		
Automatic mode / off with fade		
No function		

## 5. Miscellaneous

### 5.1 Disposal of equipment



Return old devices in accordance with the WEEE directive to suitable recycling facilities.

### 5.2 Additional information

Additional technical information at [www.tridonic.com](http://www.tridonic.com) → Technical Data

Guarantee conditions at [www.tridonic.com](http://www.tridonic.com) → Services

Lifetime declarations are informative and represent no warranty claim.  
No warranty if device was opened.